

SINGER
47K1,K3,K5

Form K5491
Supersedes K1689
(1038)
Printed in Great Britain

ILLUSTRATED
LIST OF PARTS
FOR
CLASS 47K MACHINES
(Nos. 47K1, 47K3 and 47K5)



THE SINGER MANUFACTURING COMPANY

All Rights Reserved

From the library of: Diamond Needle Corp

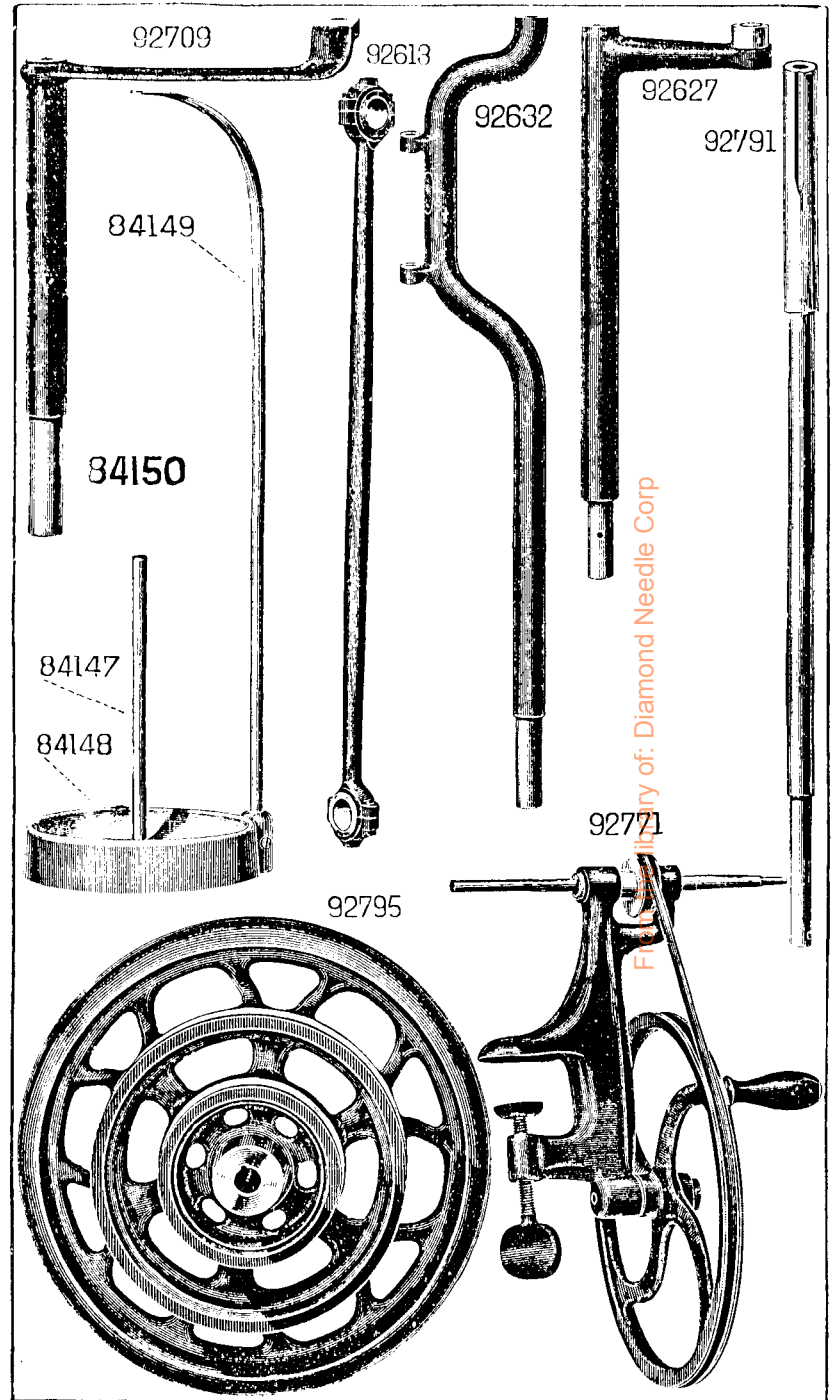

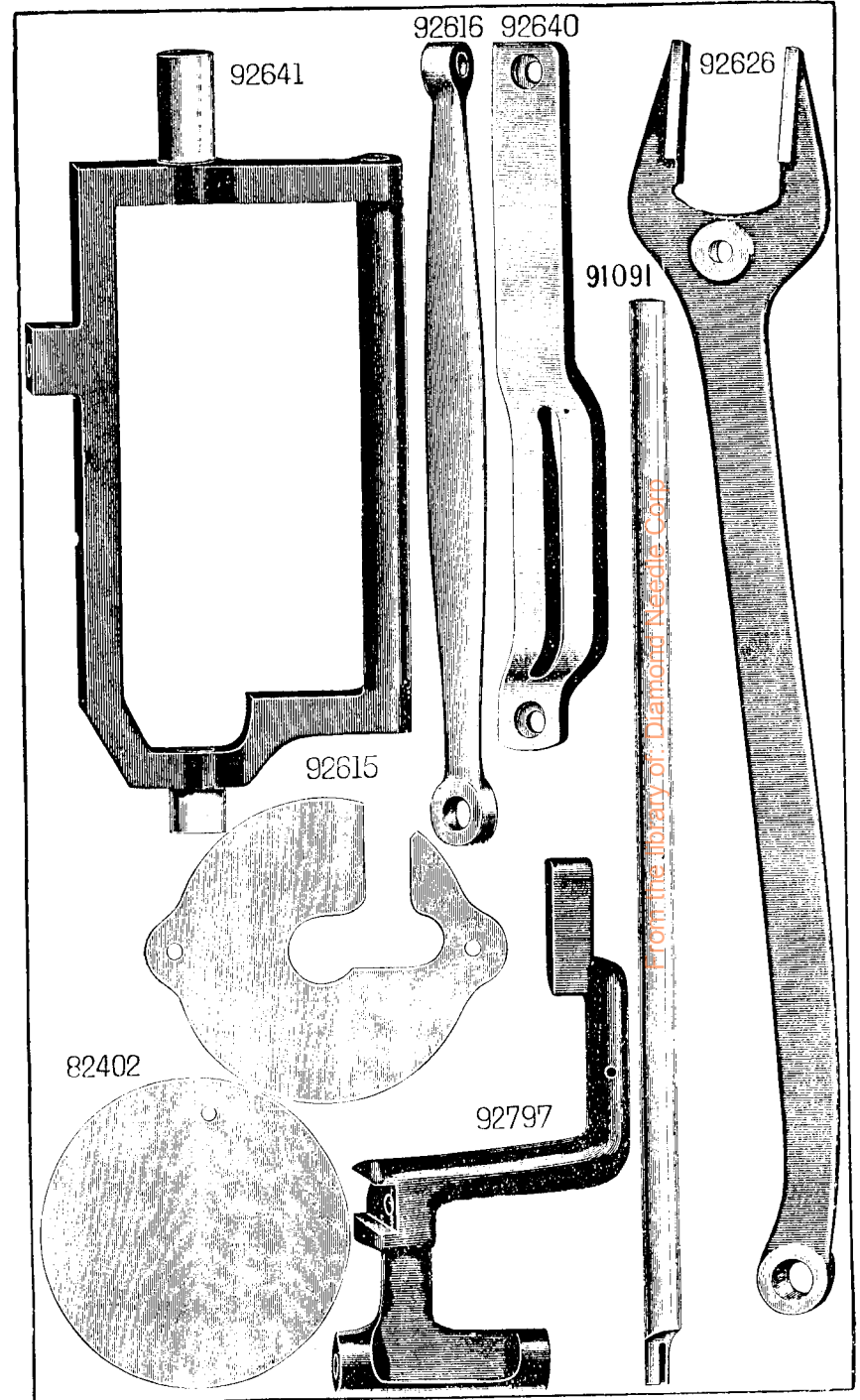
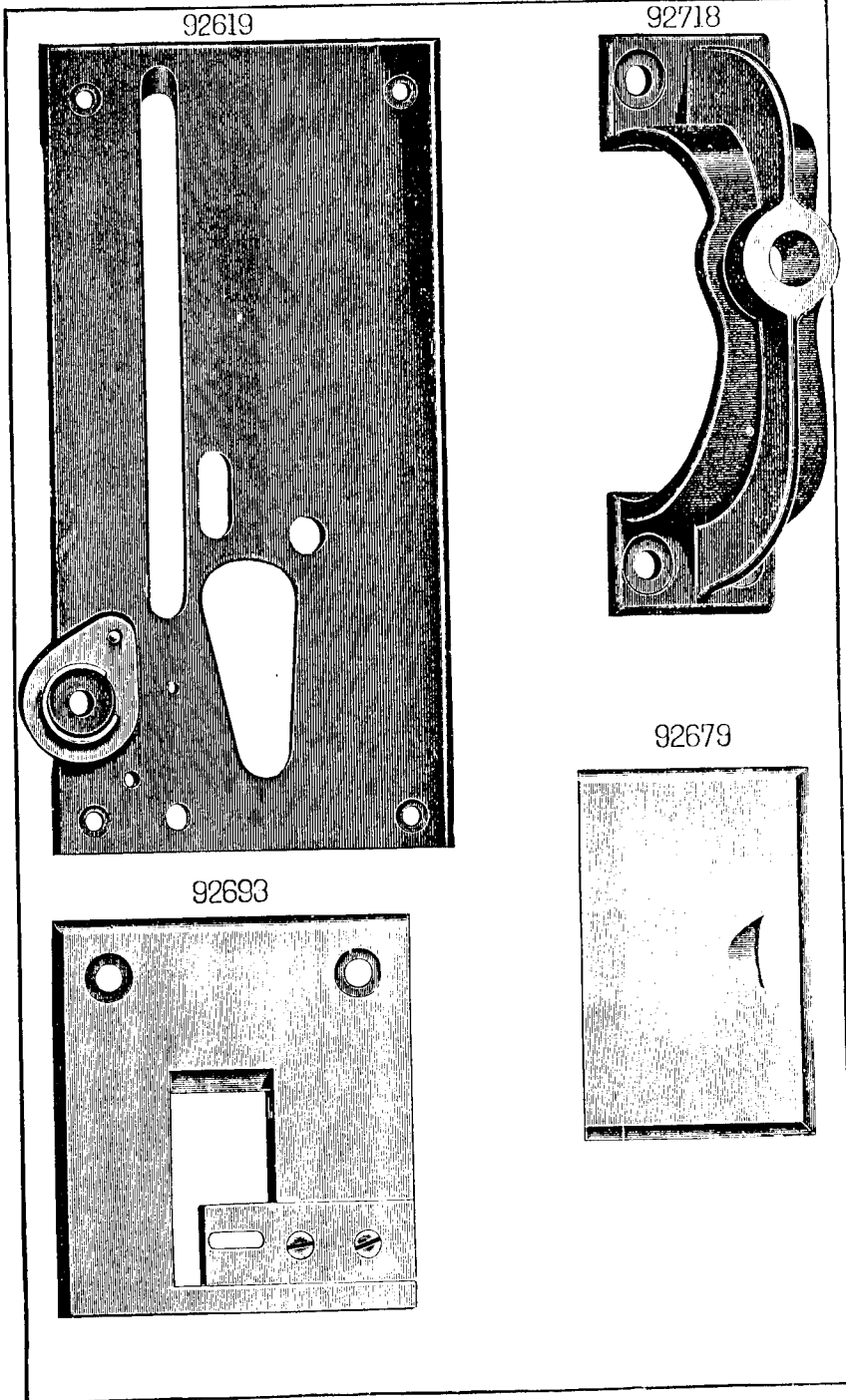

From the library of Diamond Needle Corp

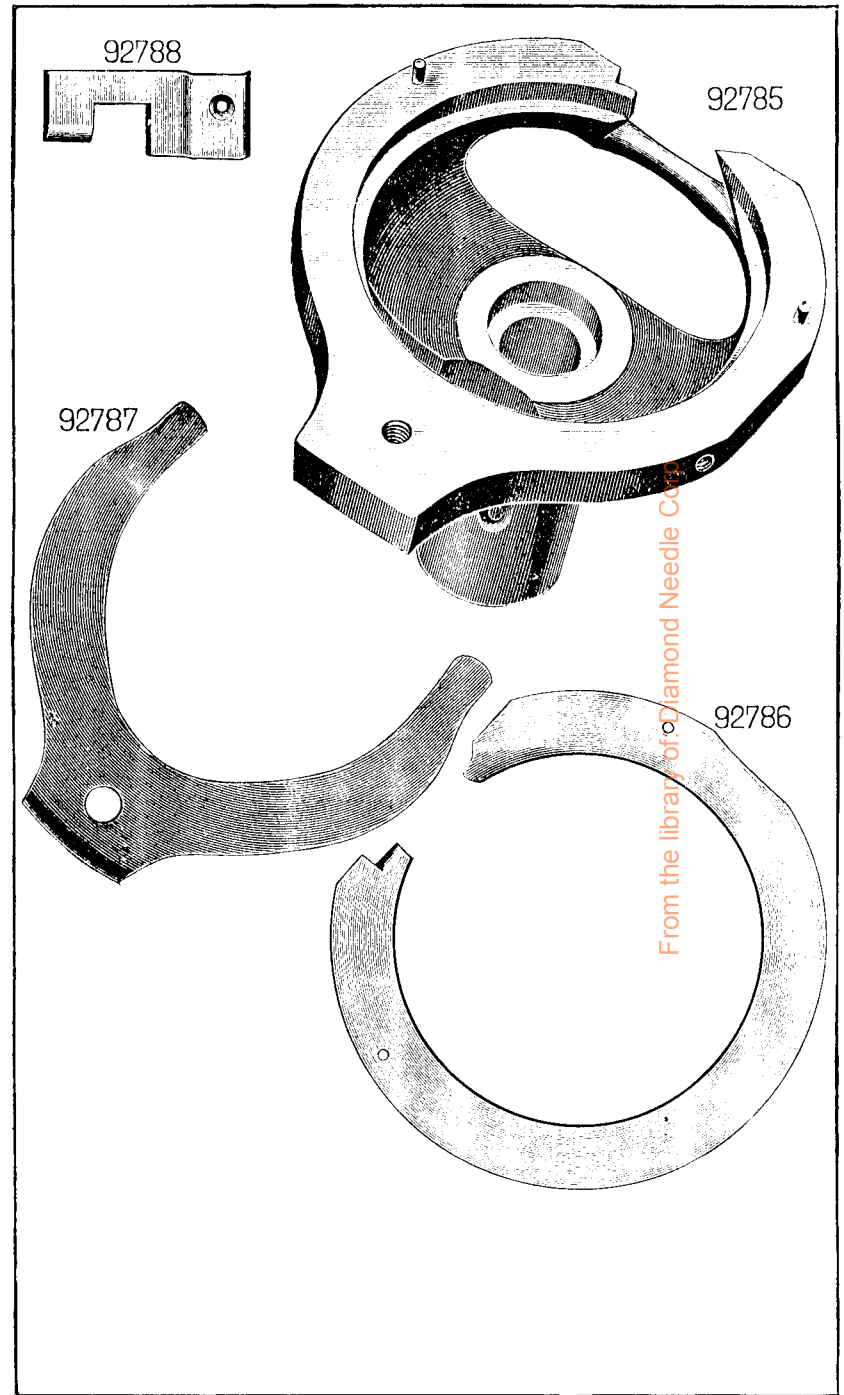
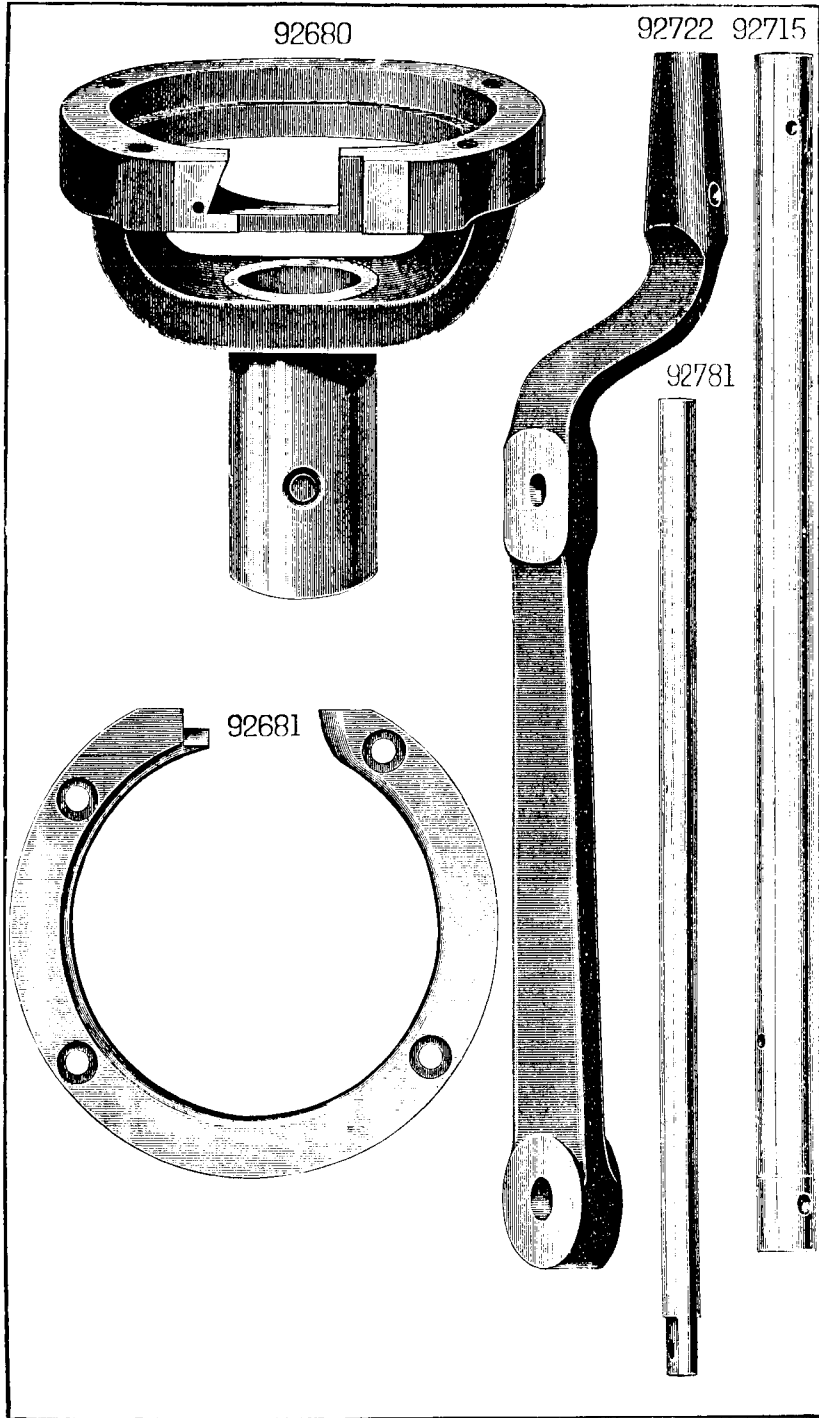

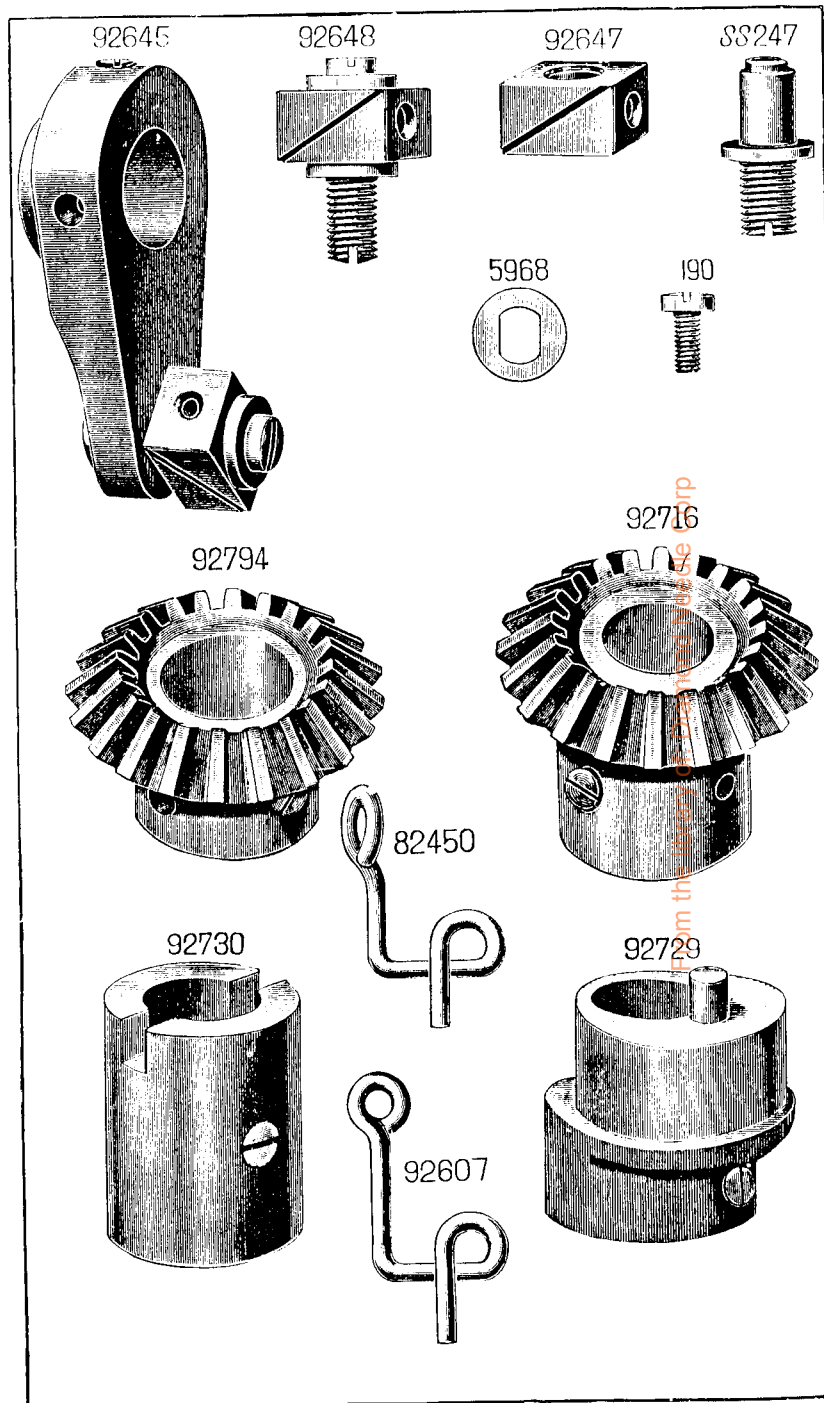
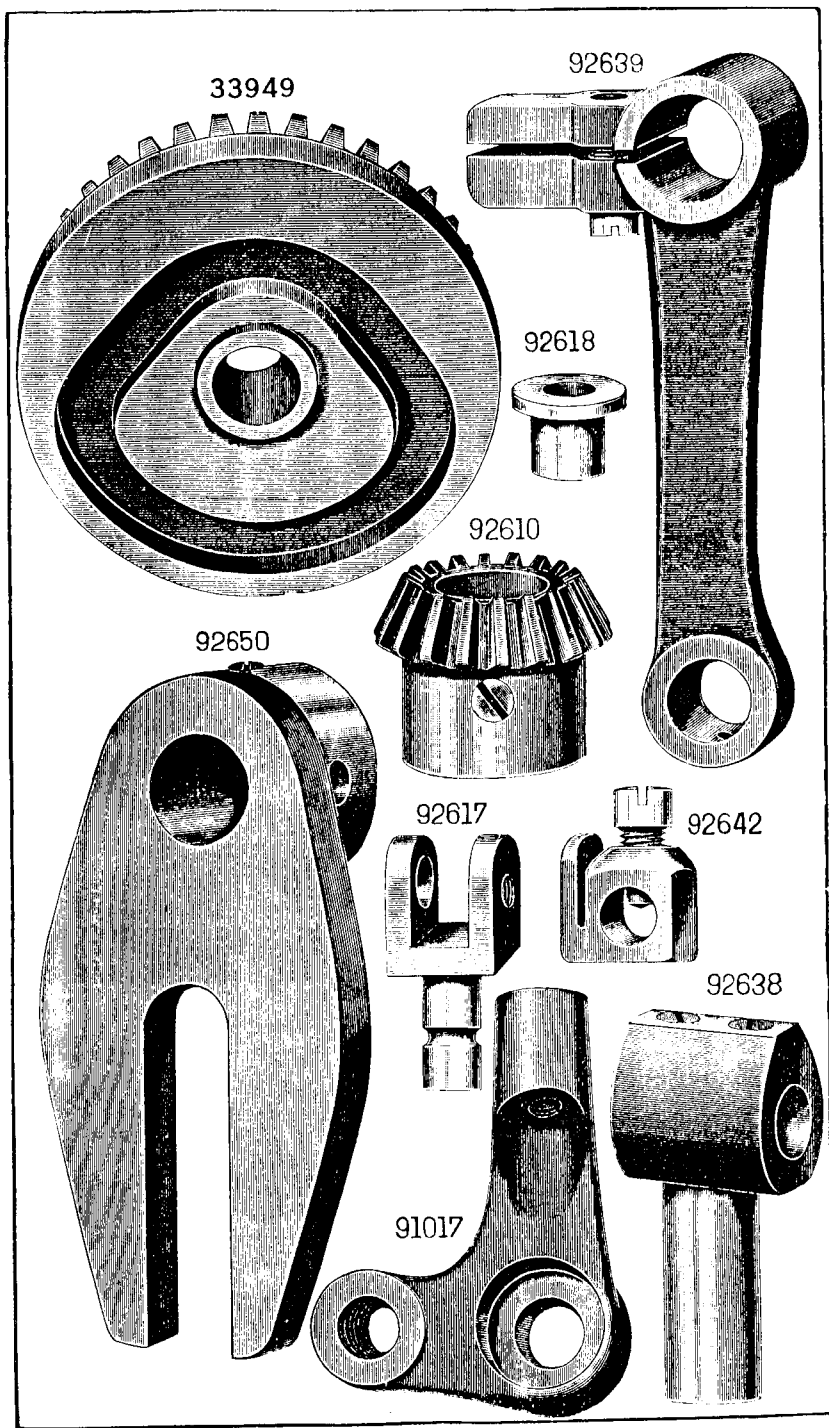

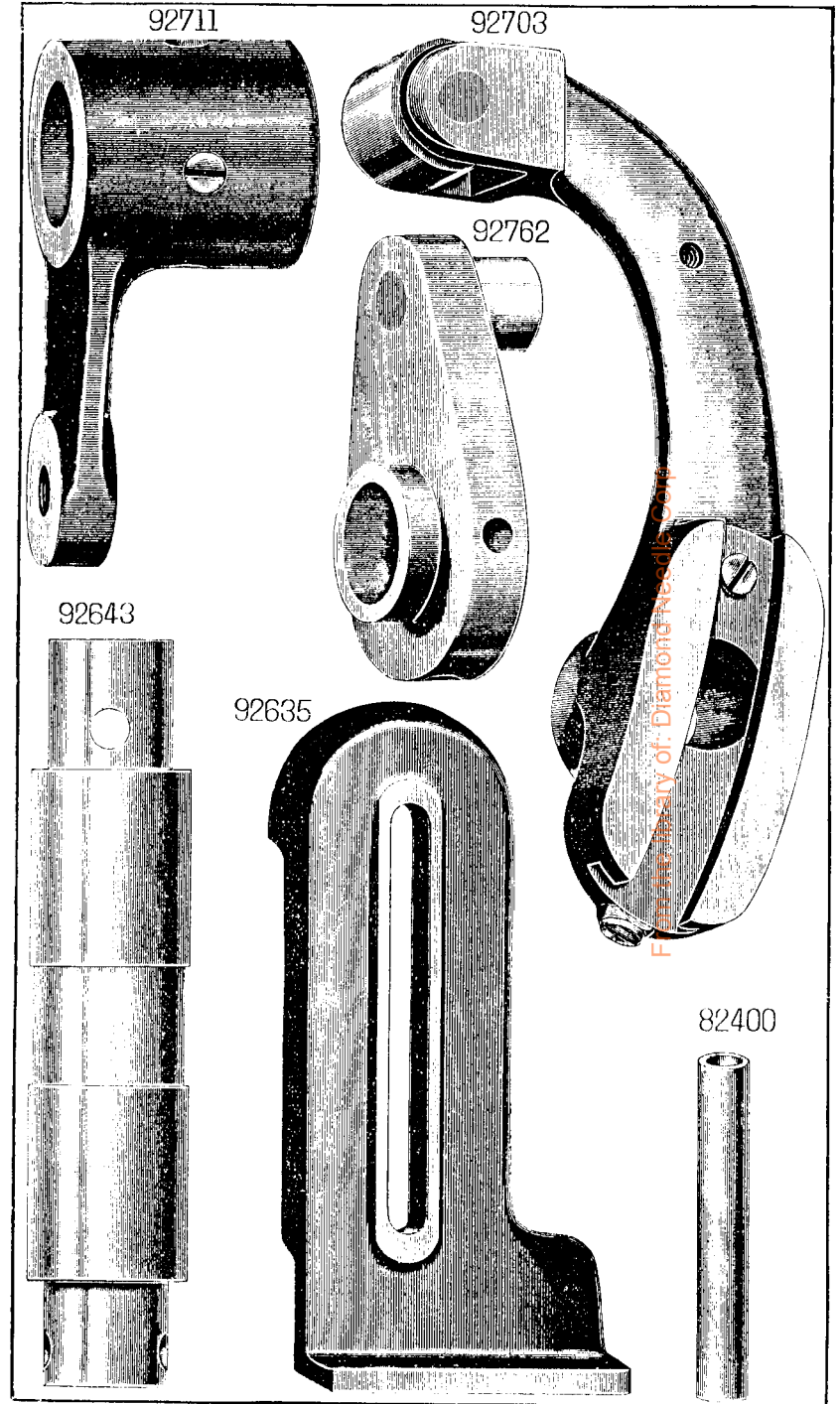
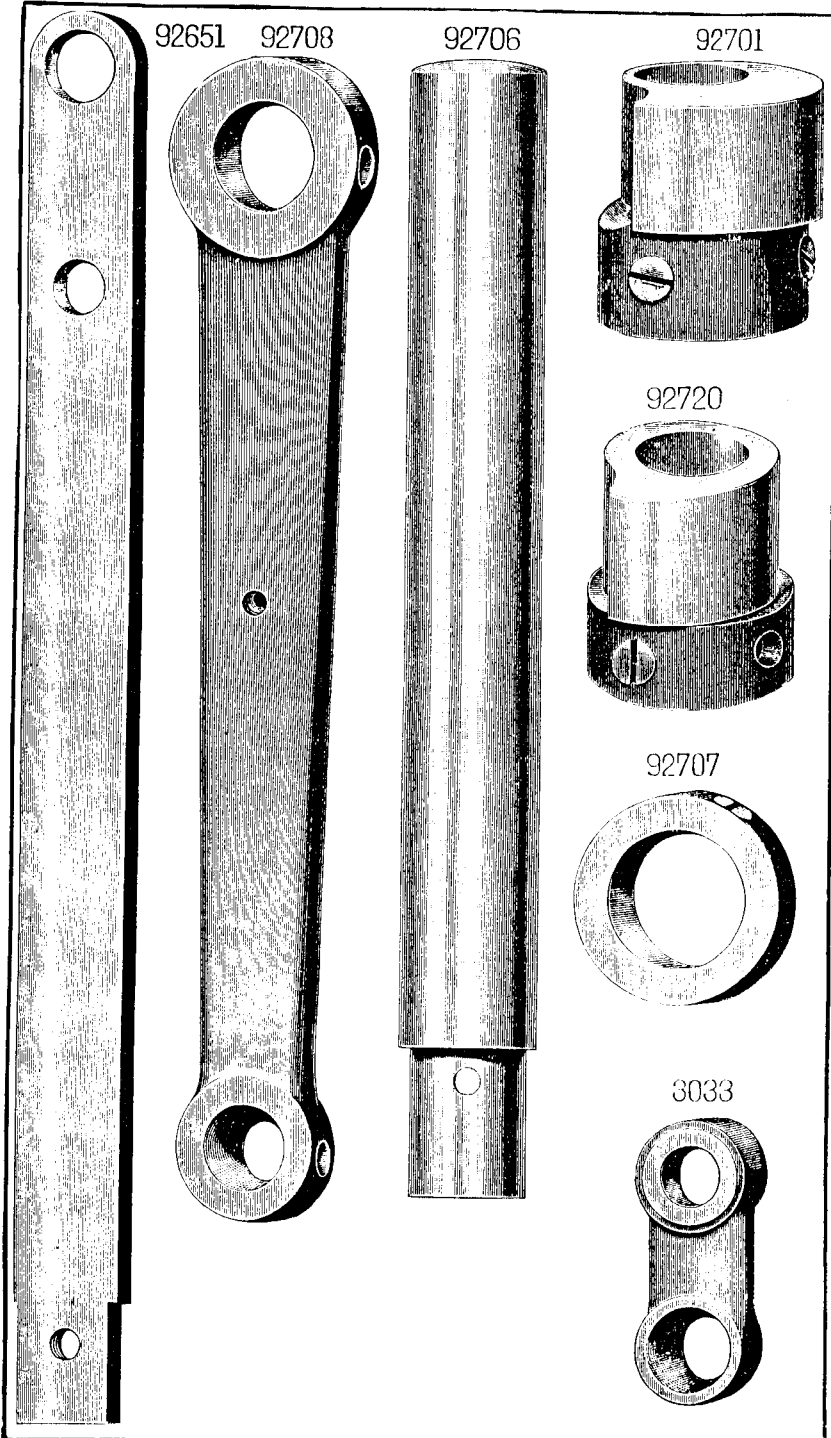

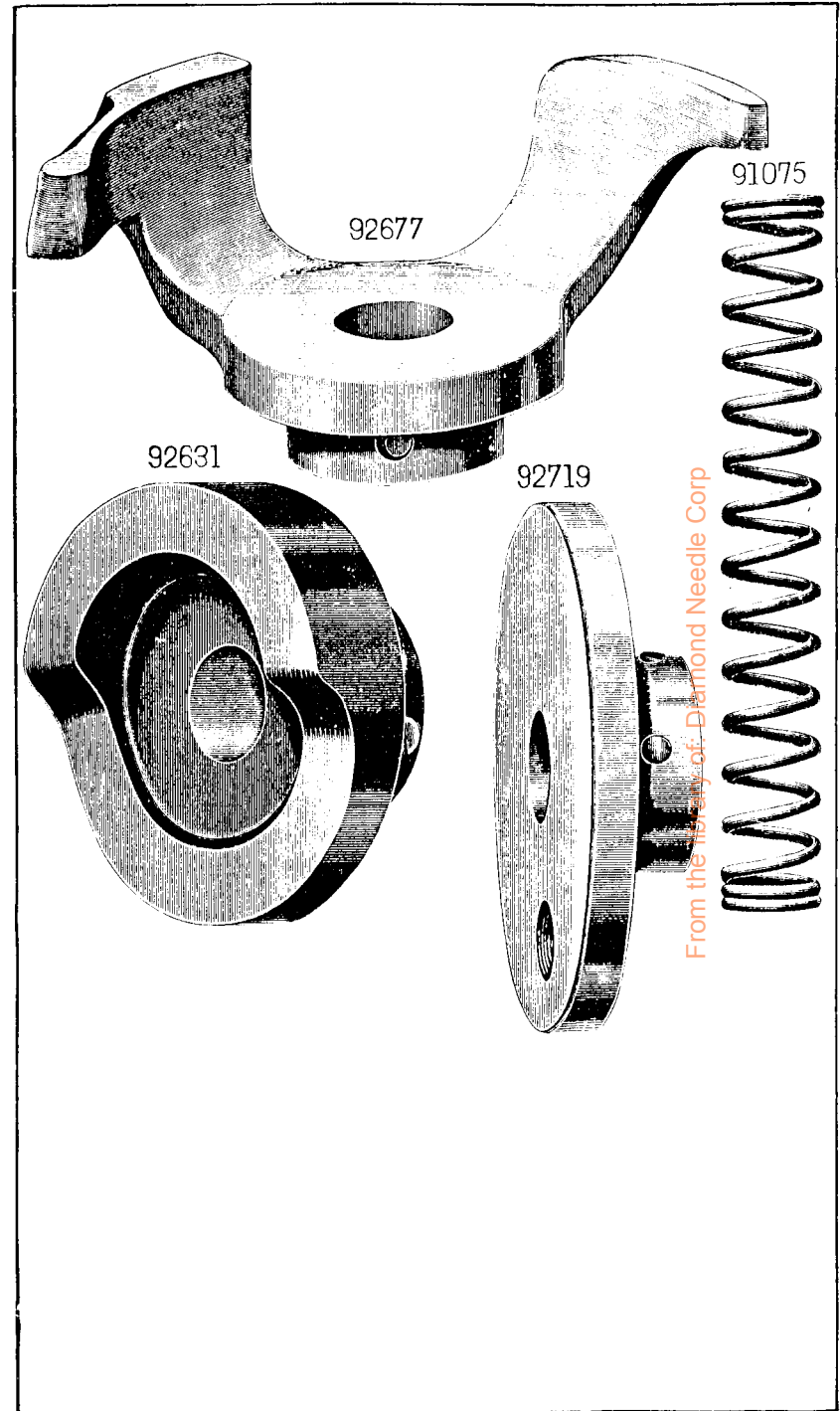
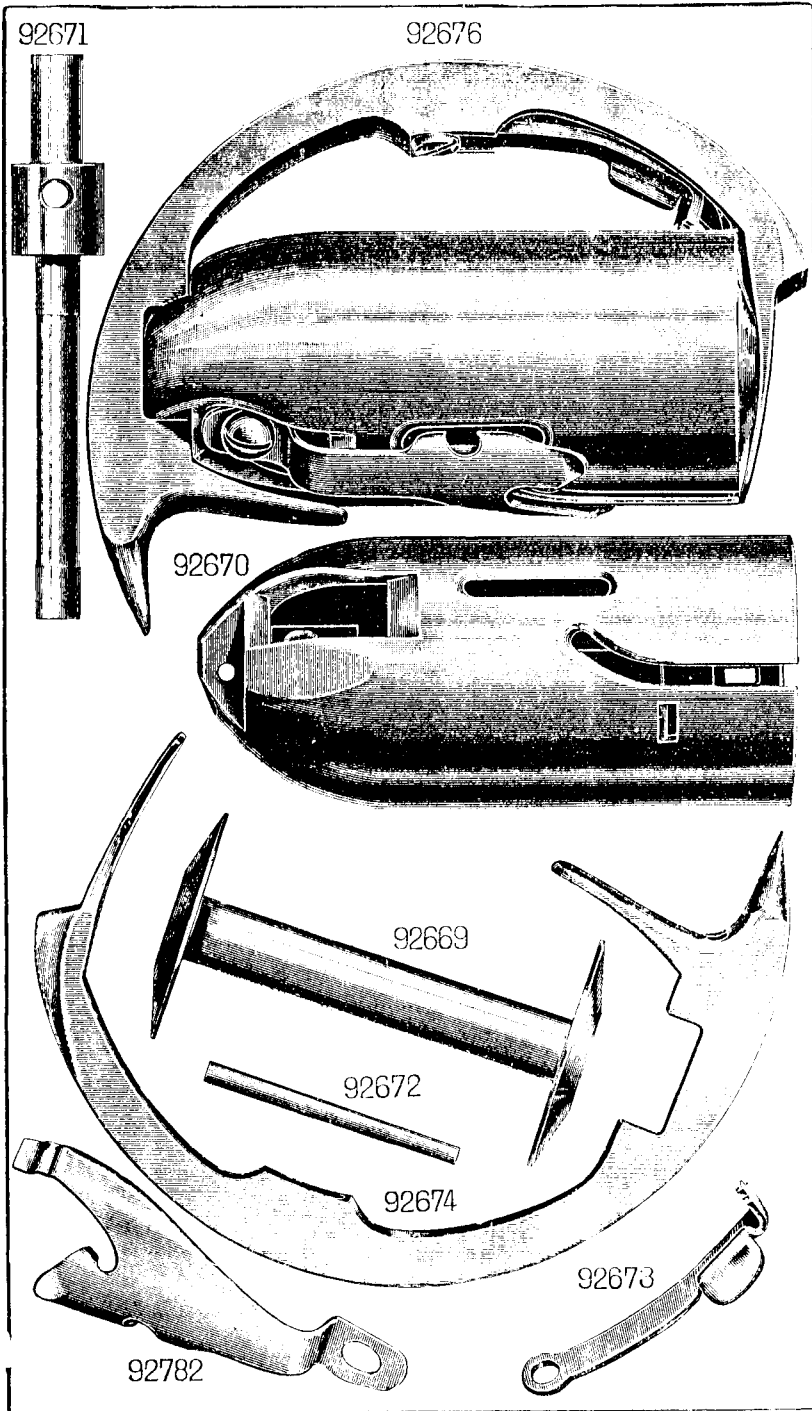

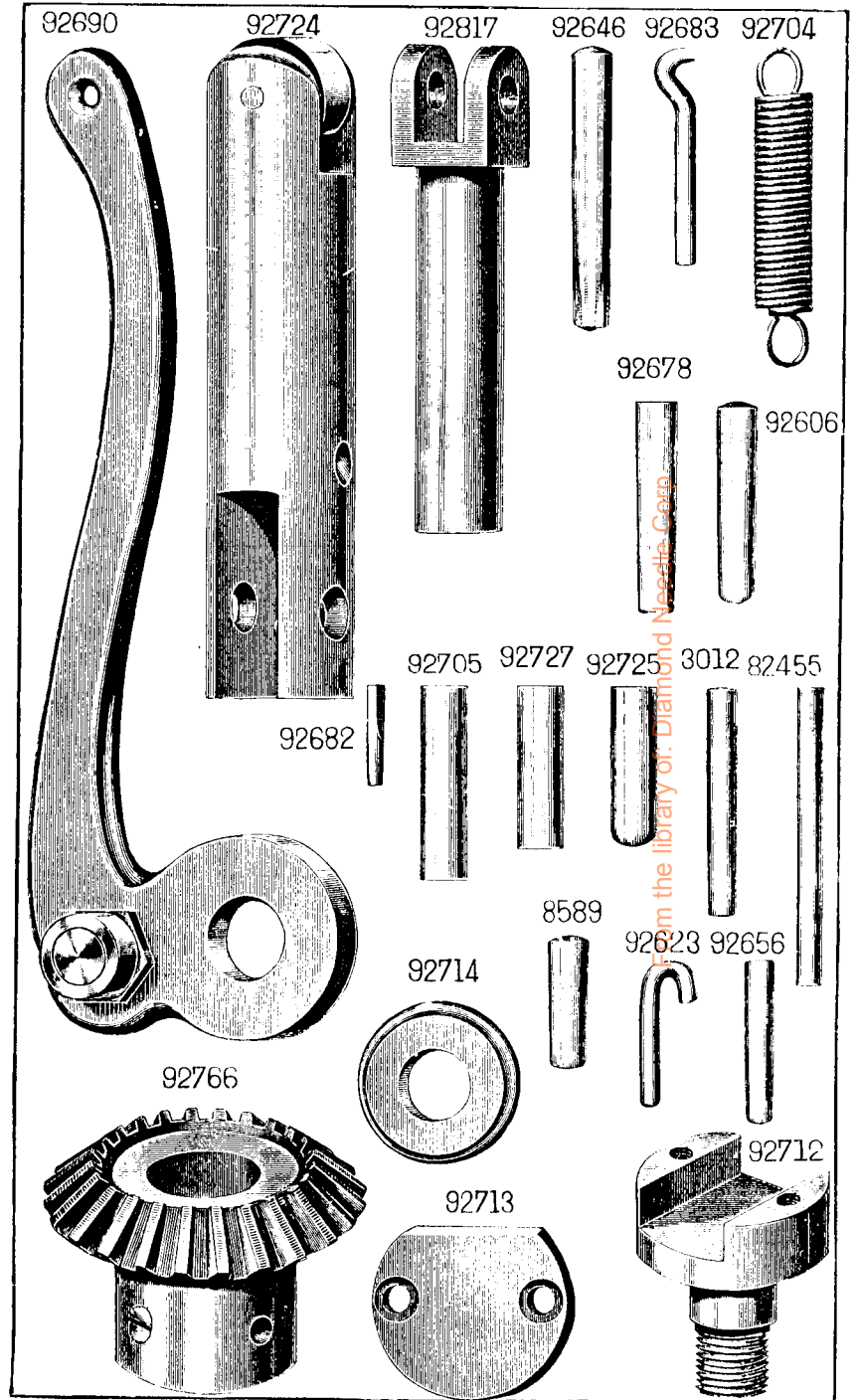
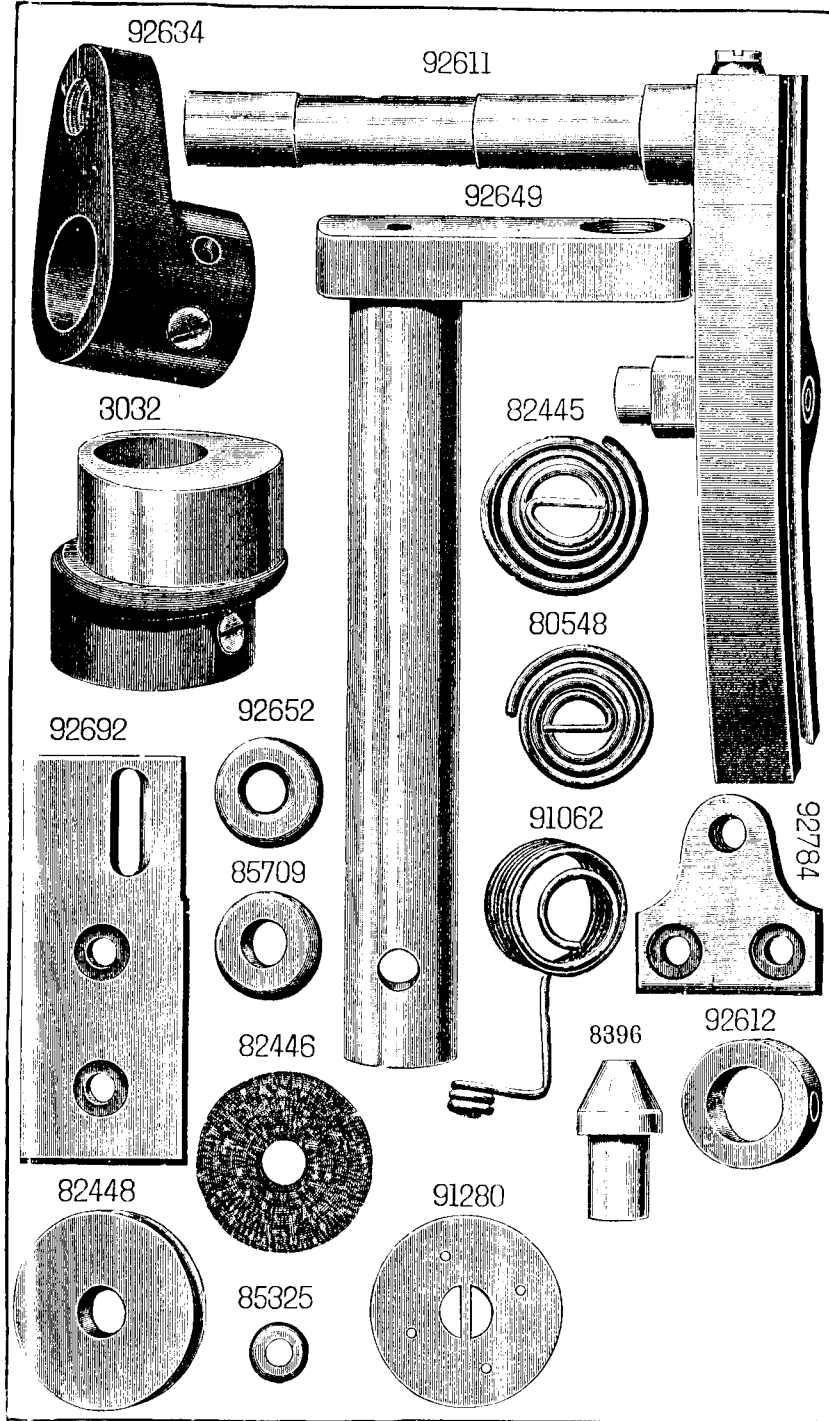

from the library of: Diamond Needle Co.

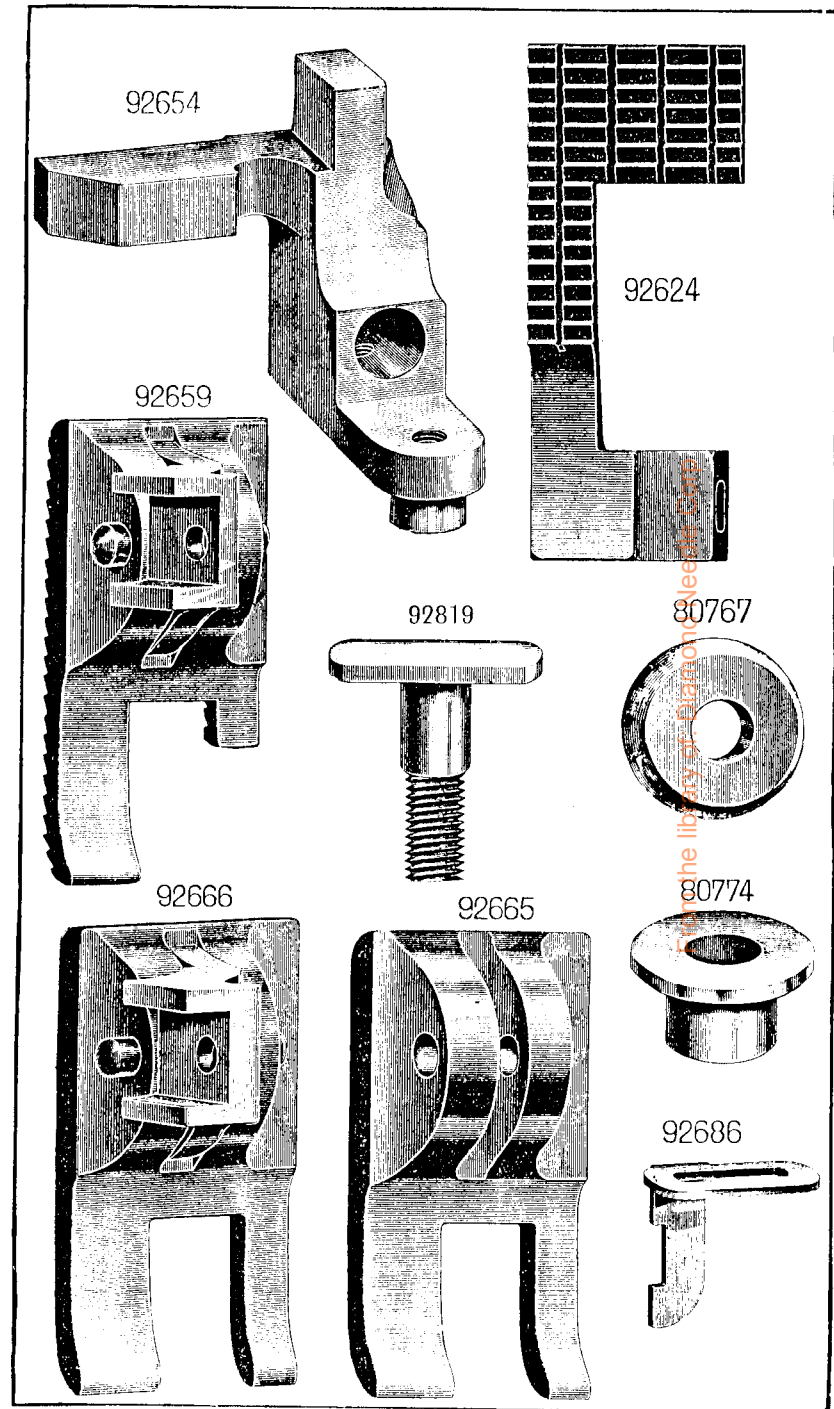
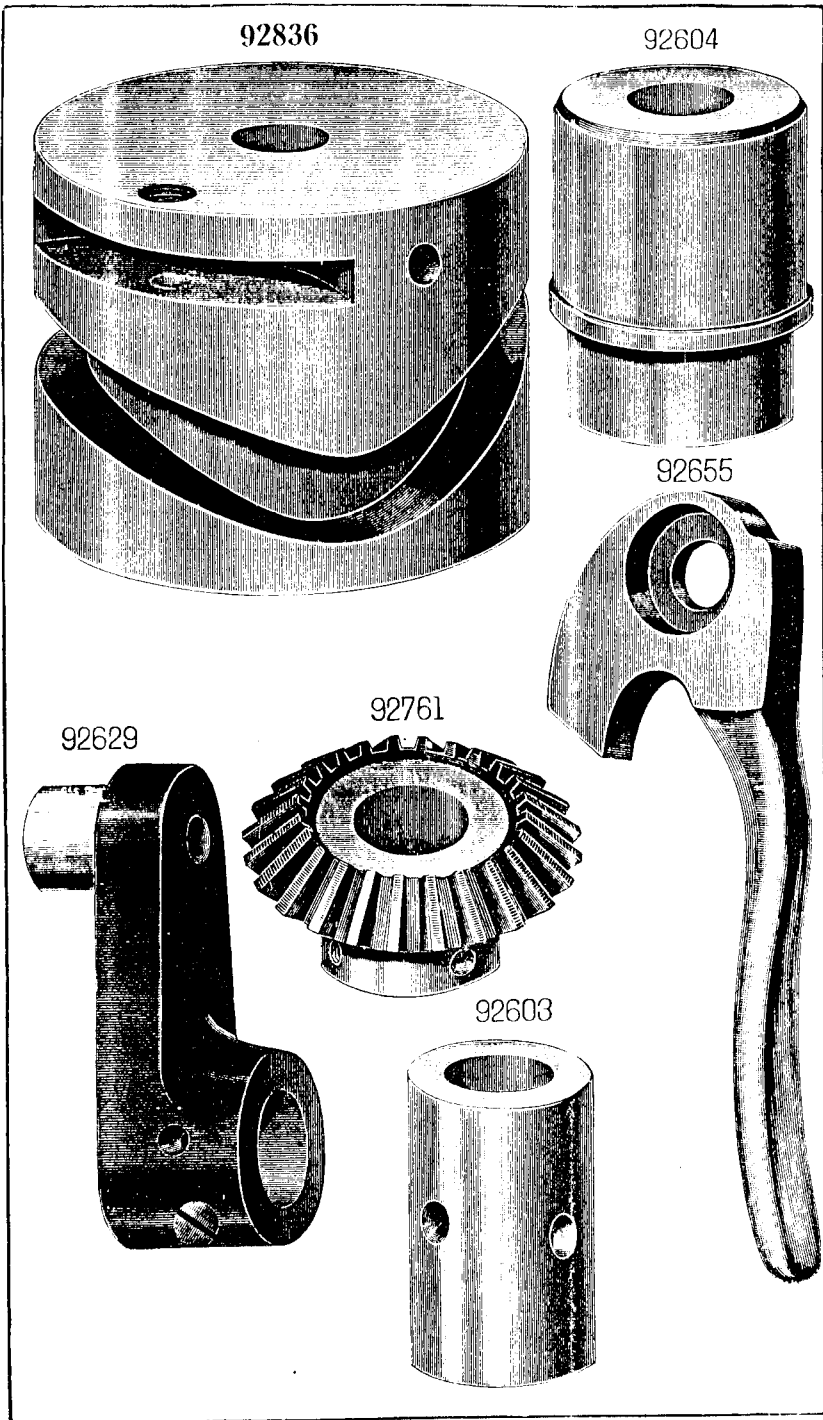

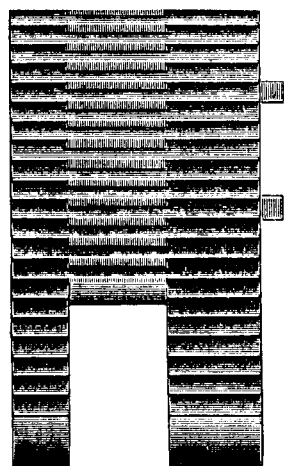

92661

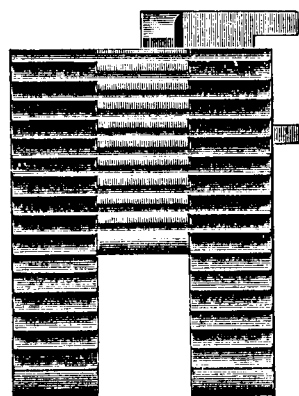
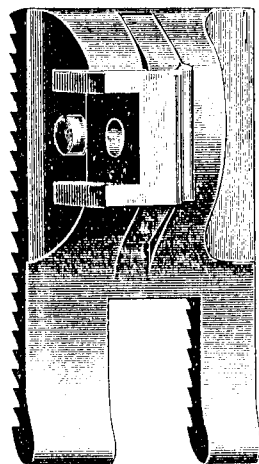

92664

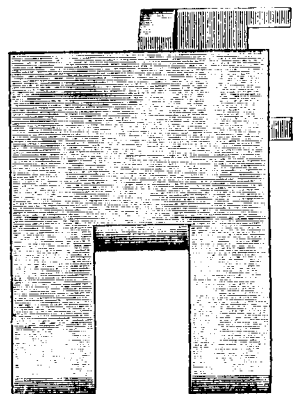
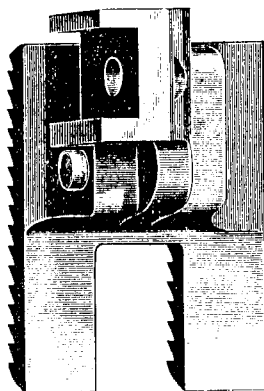

92668

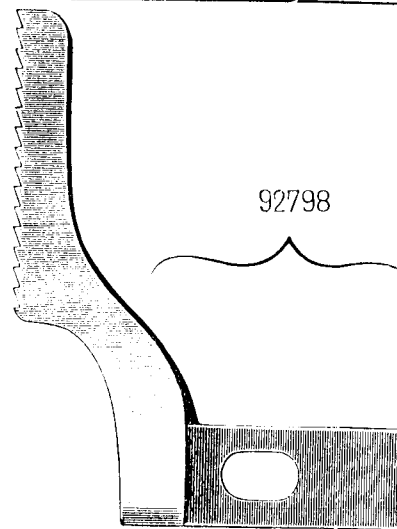
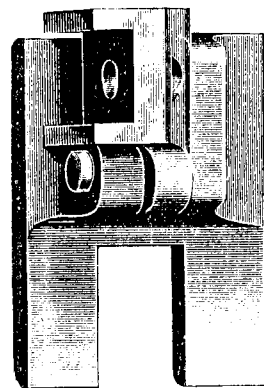

92798

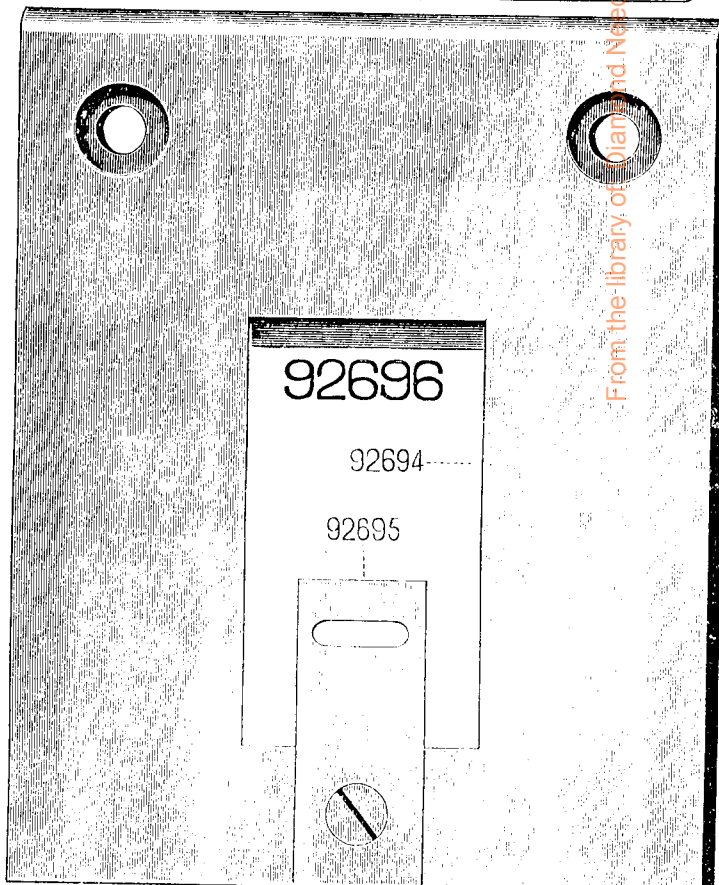
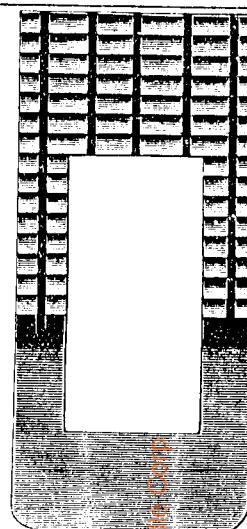

92696

92694

92695

From the library of *Qian and Neelke Doorn*

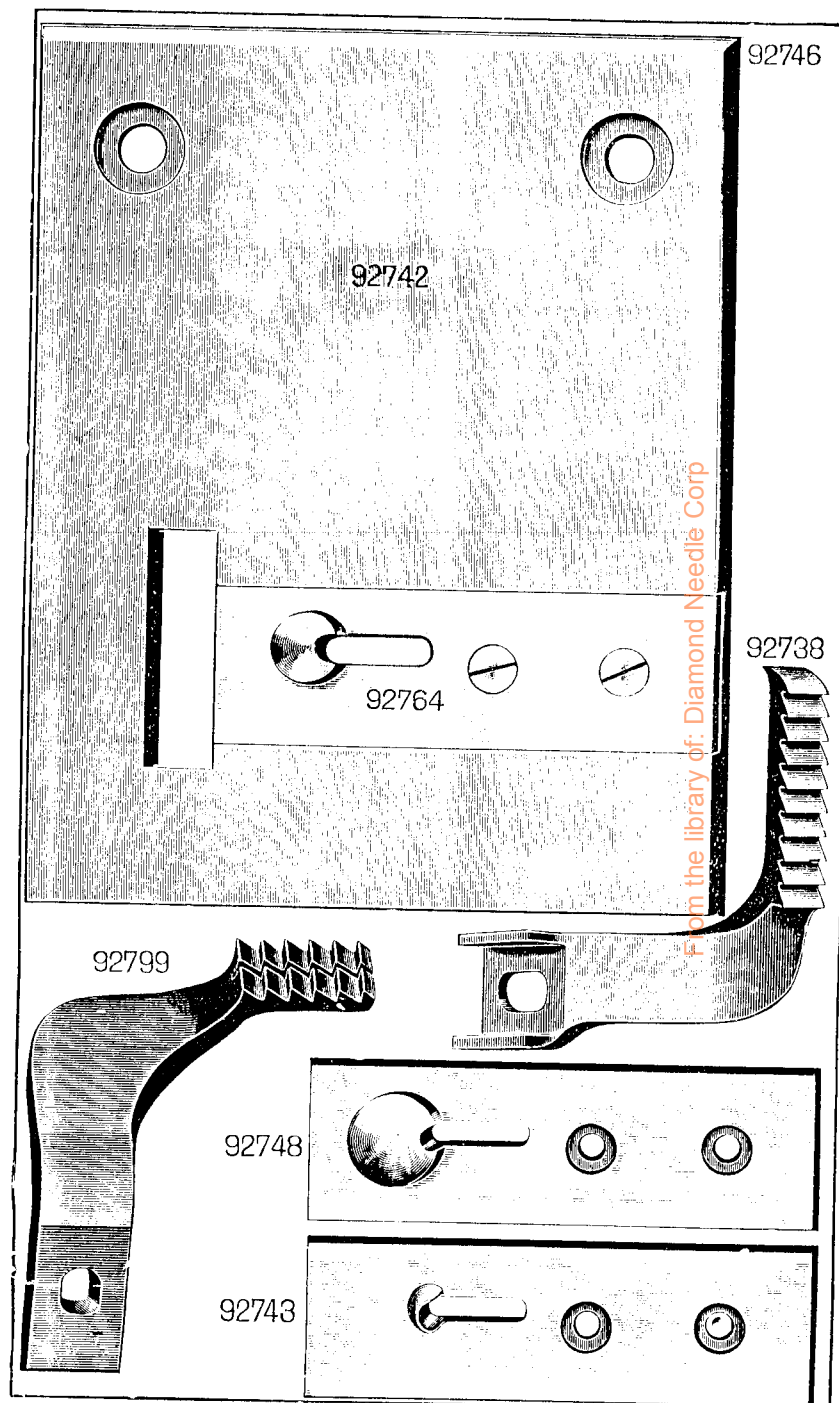
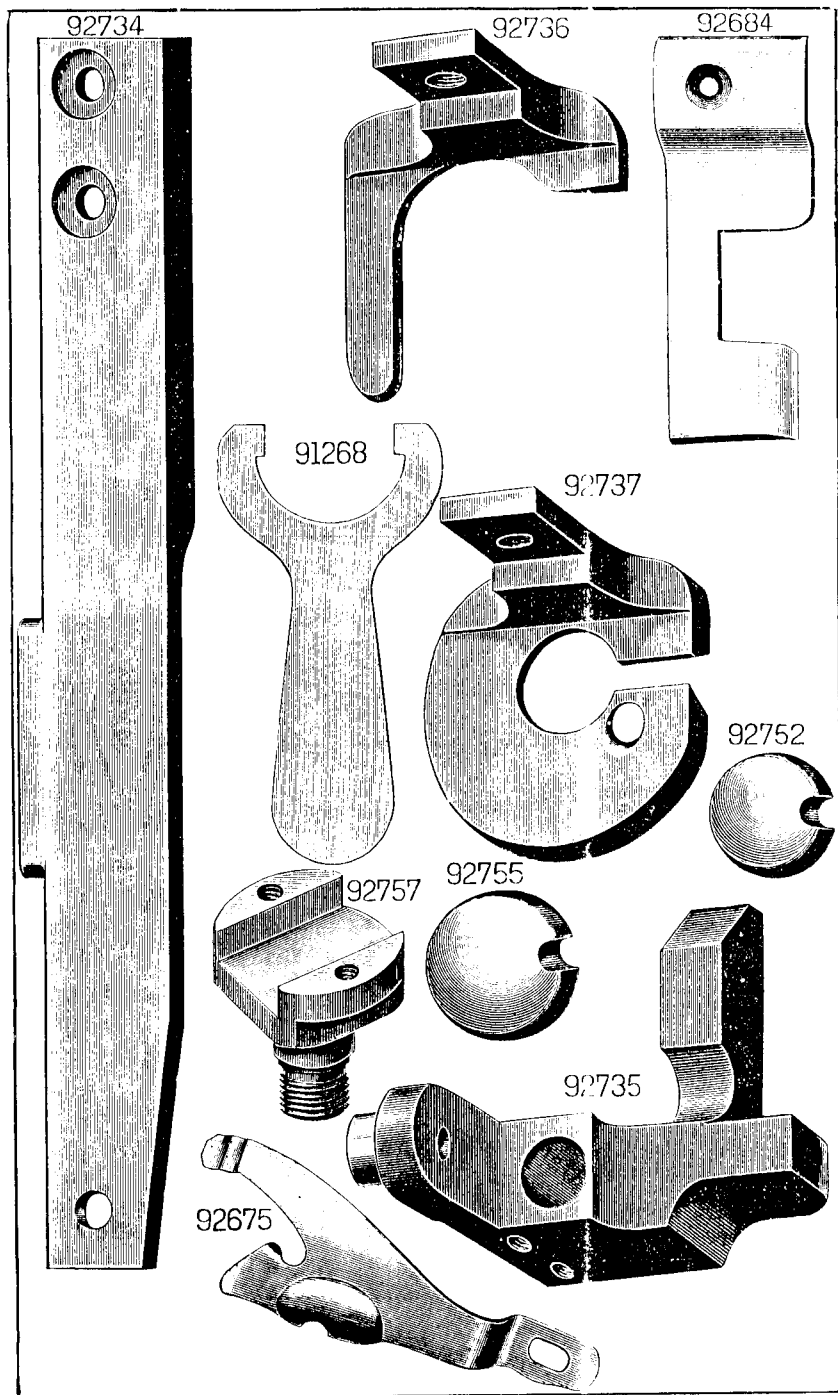

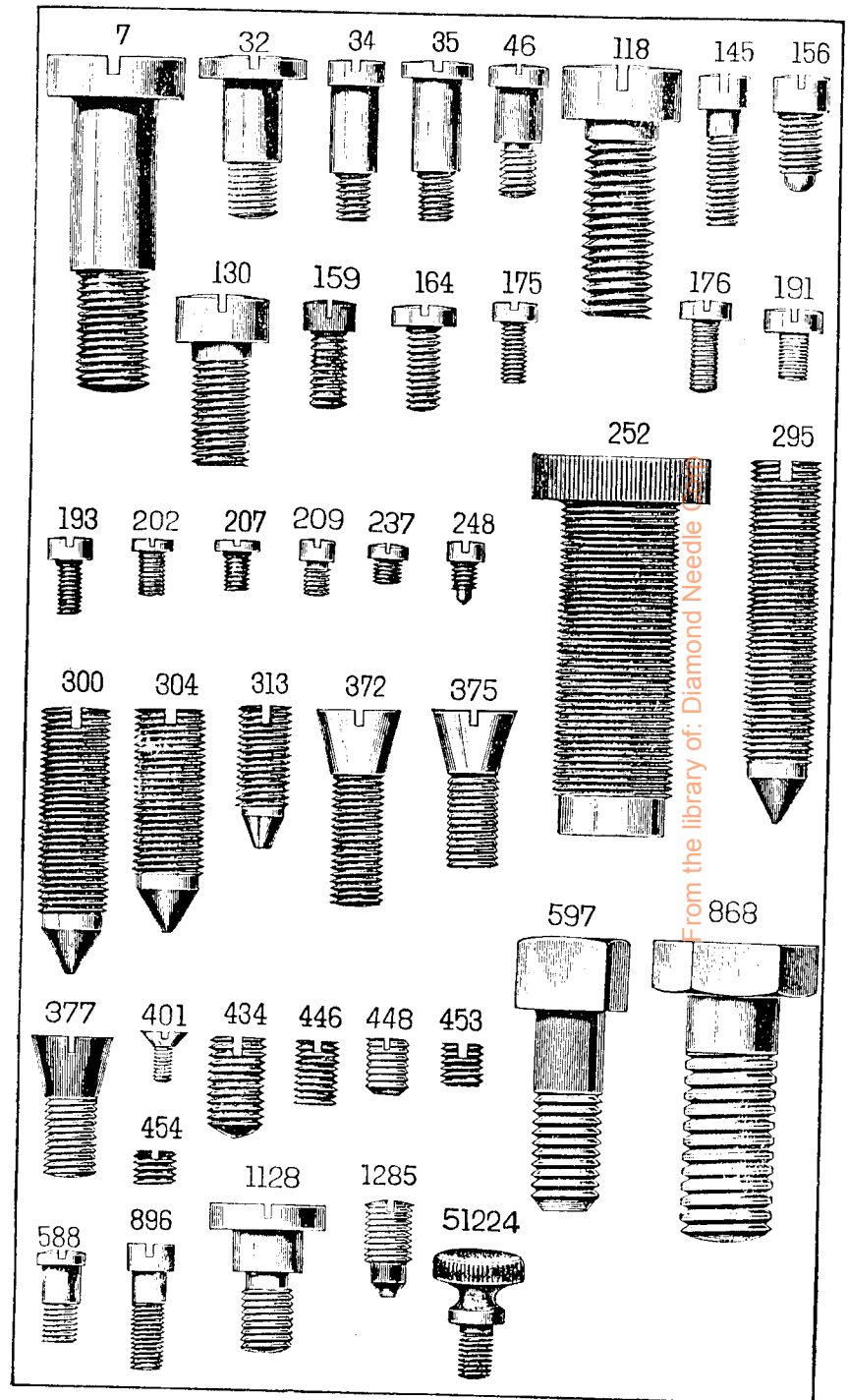
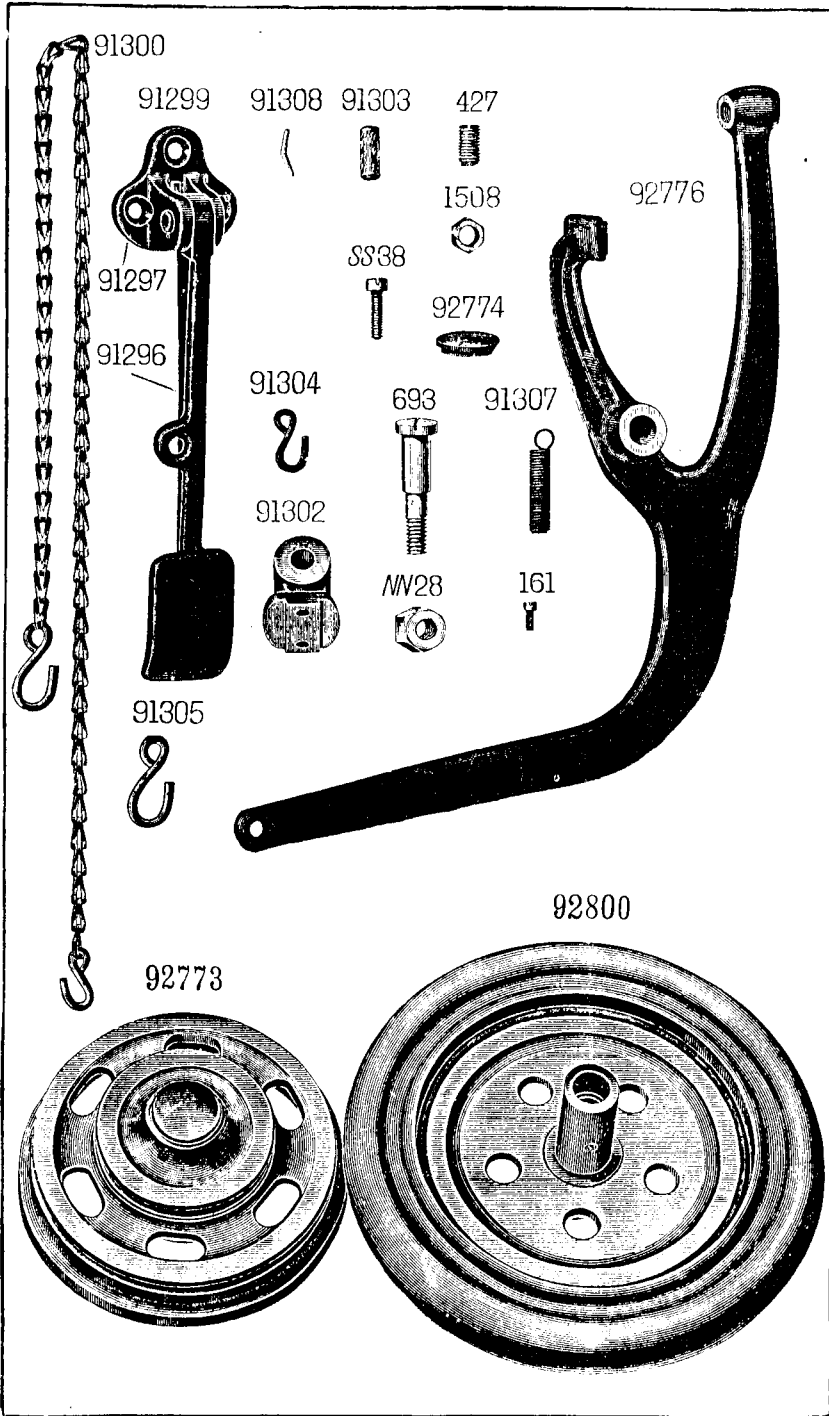

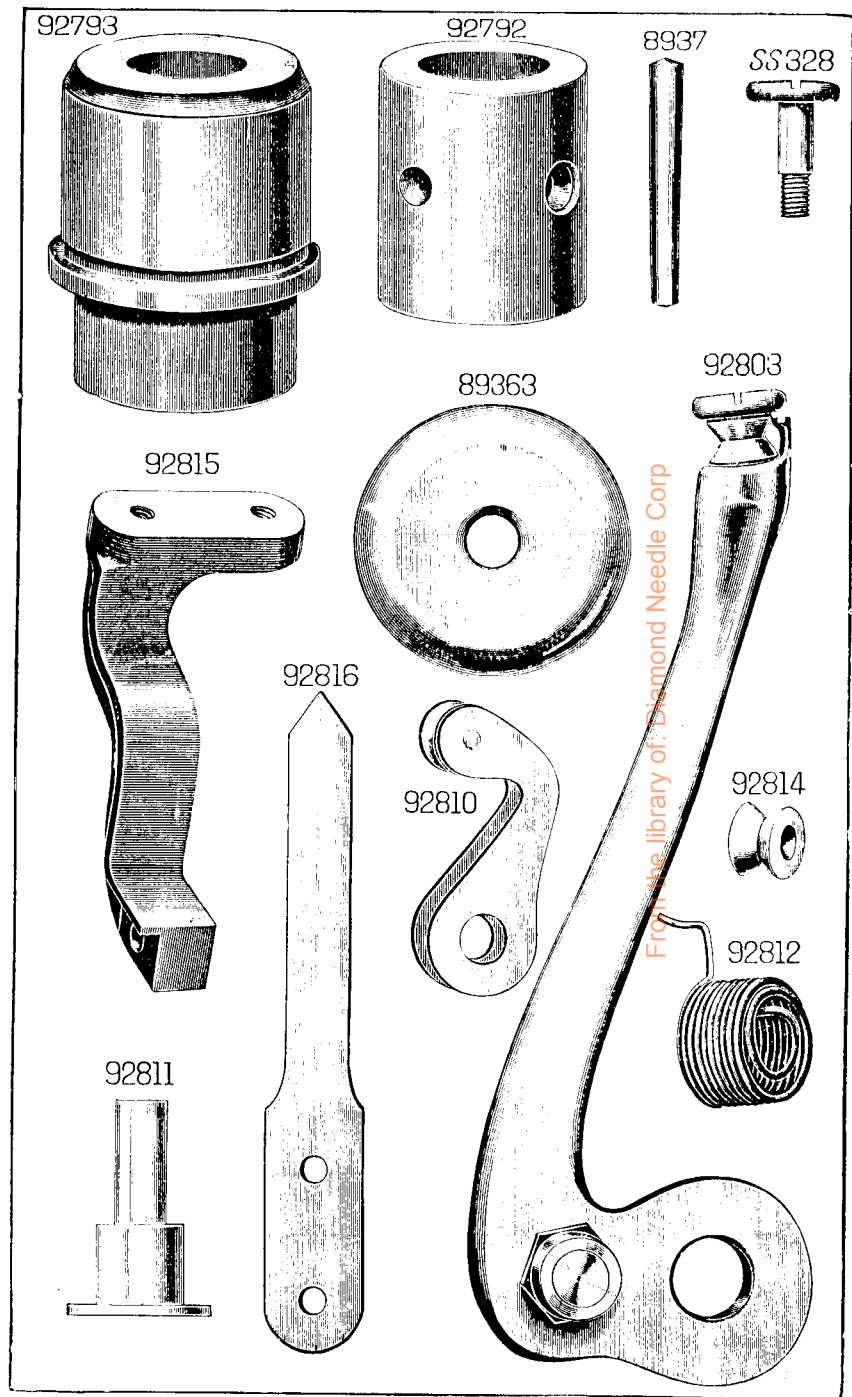
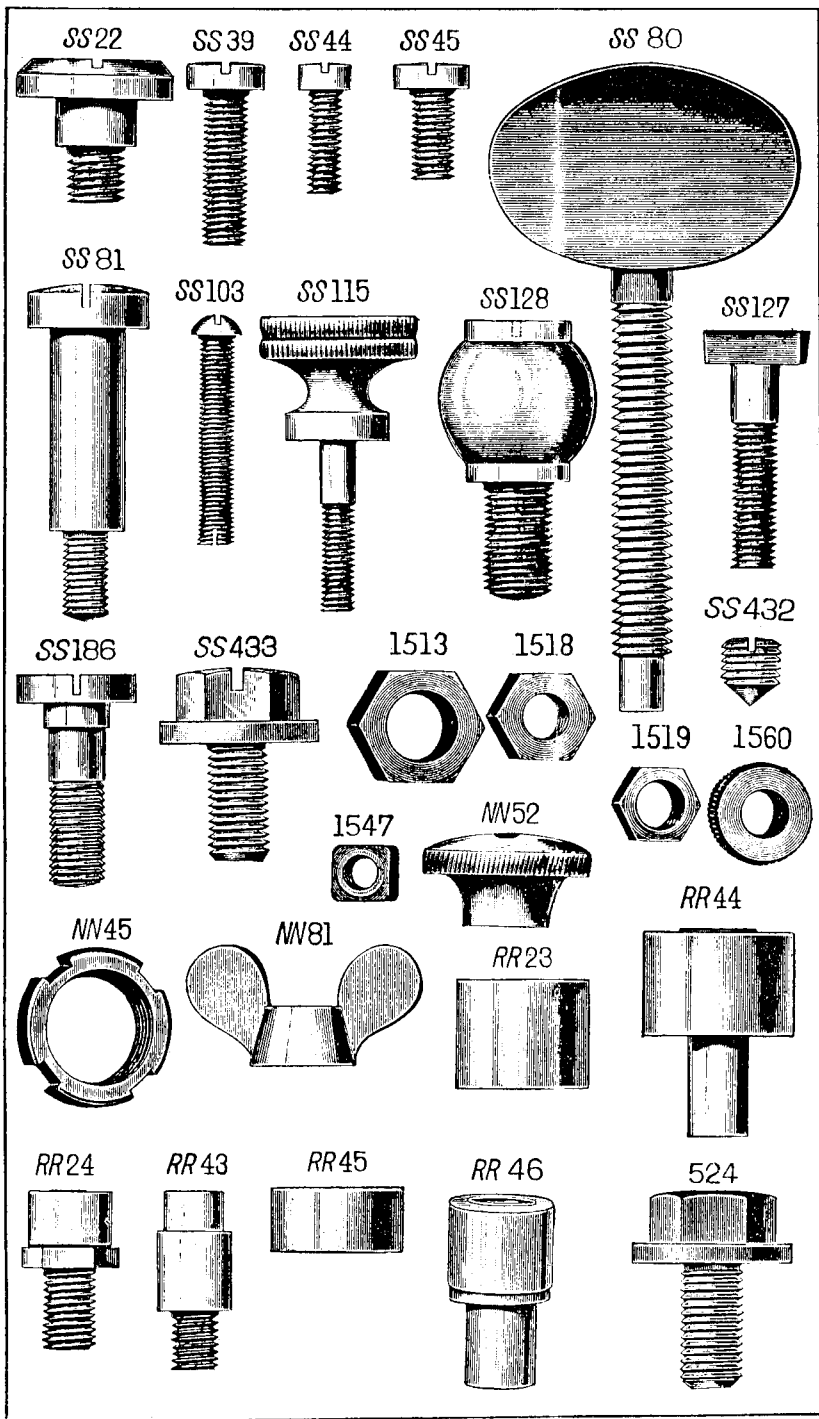

92806

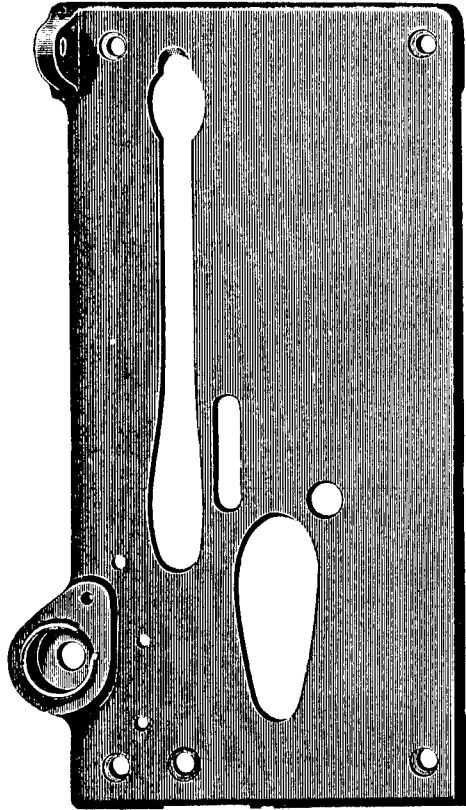

92826 -

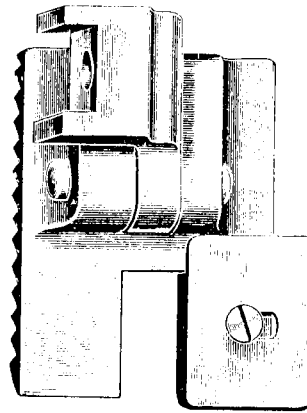

92828

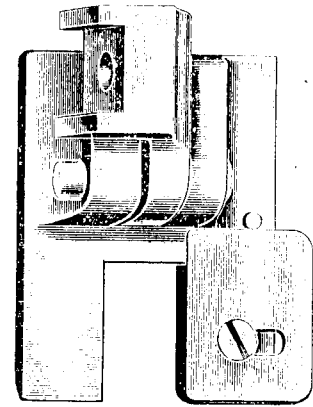

92829

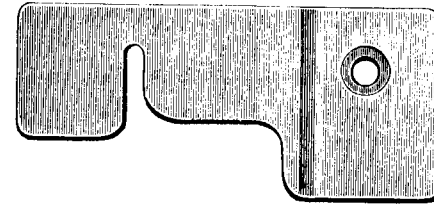

92832

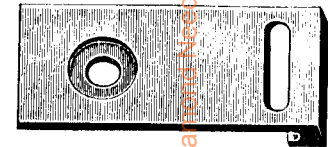

92831

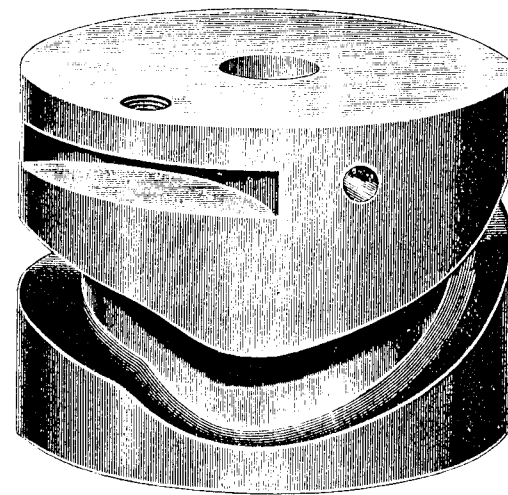

92834

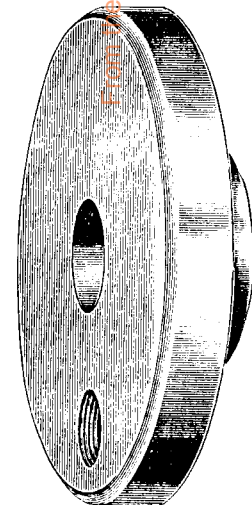

From the Library of: Diamond Drill Corp

86611



120342

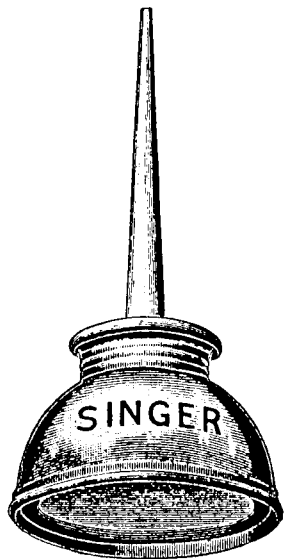

92823

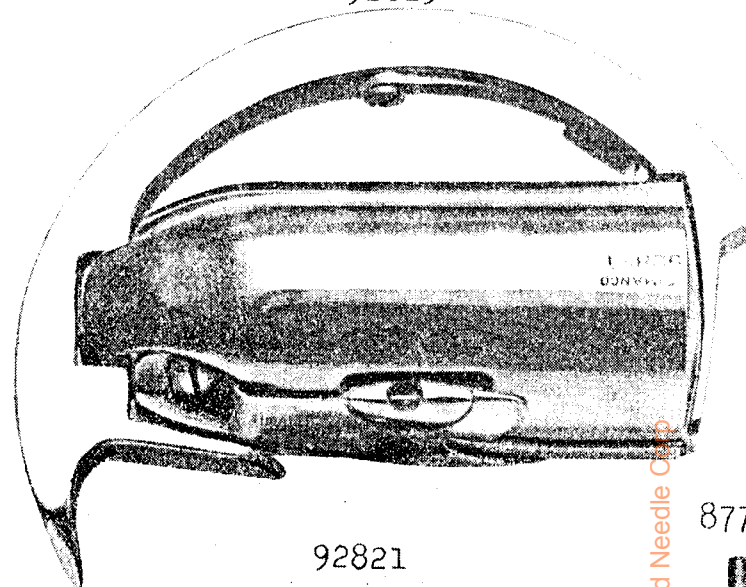

92821

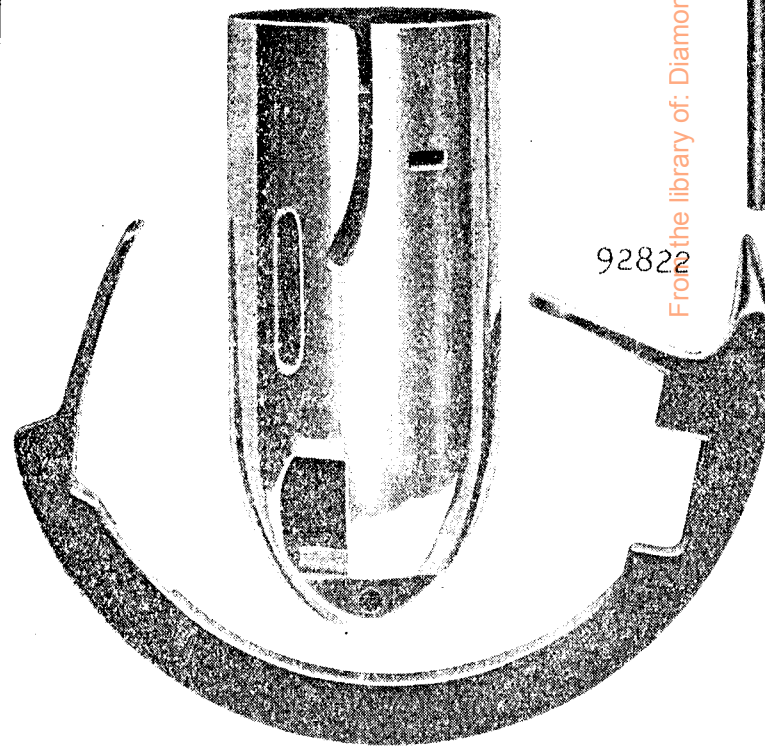

8777

92822

From the library of: Diamond Needle Co.

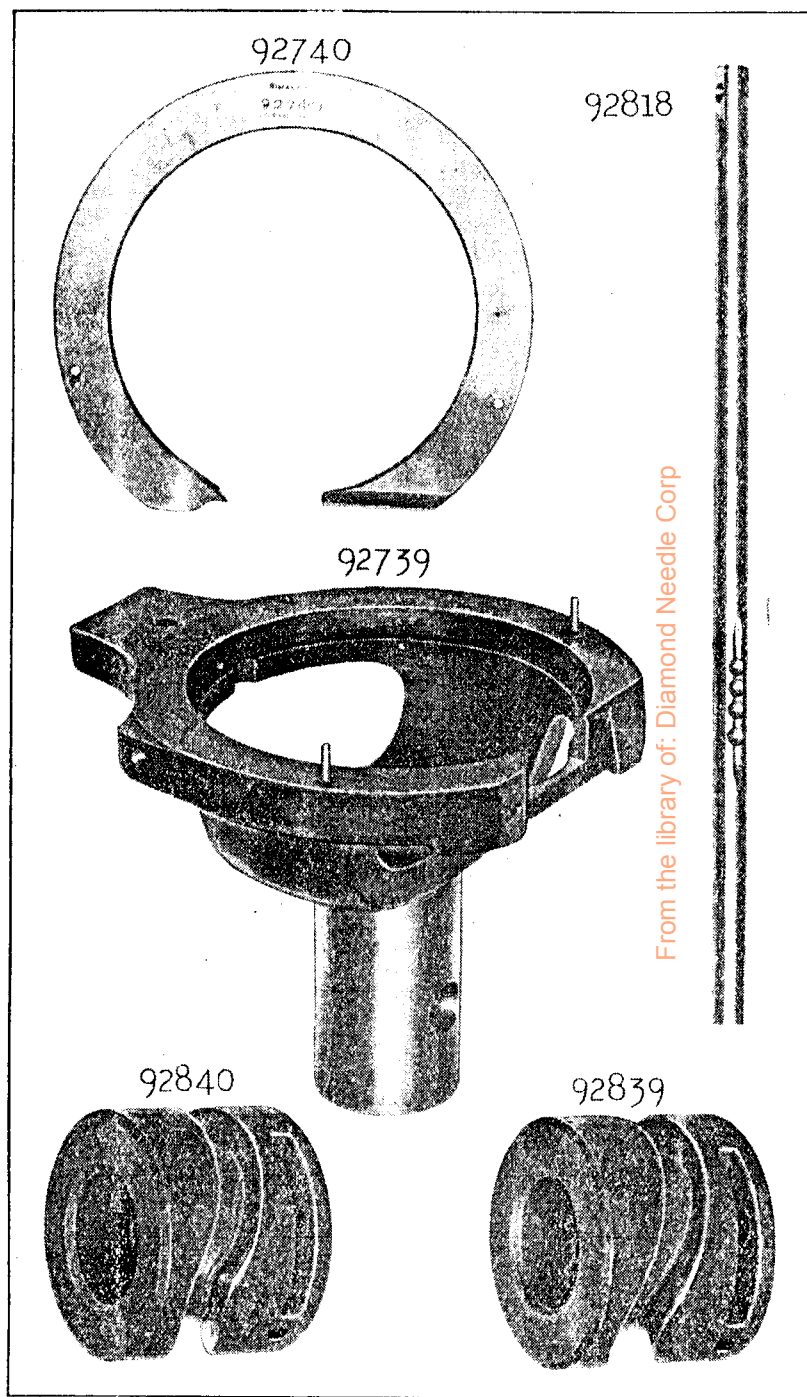
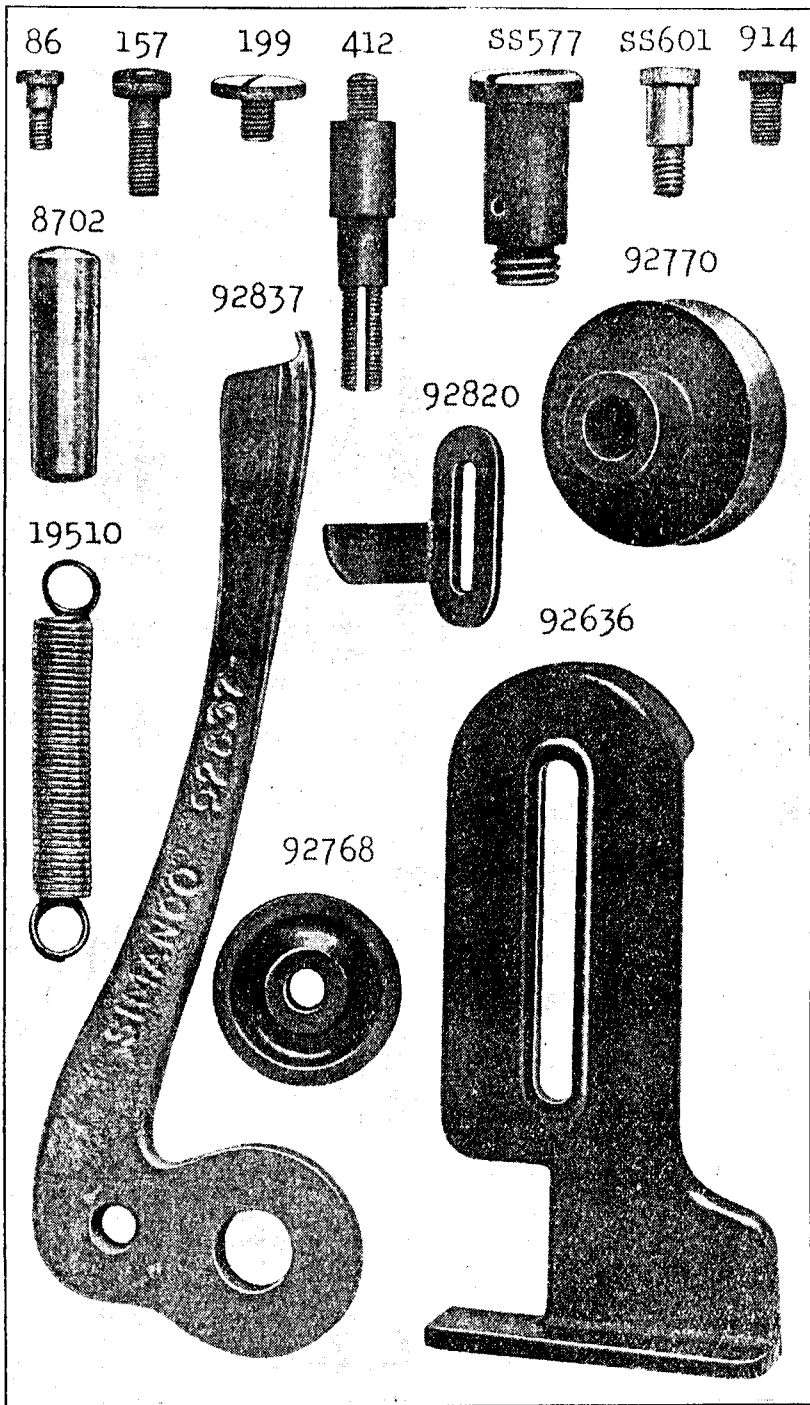

92779

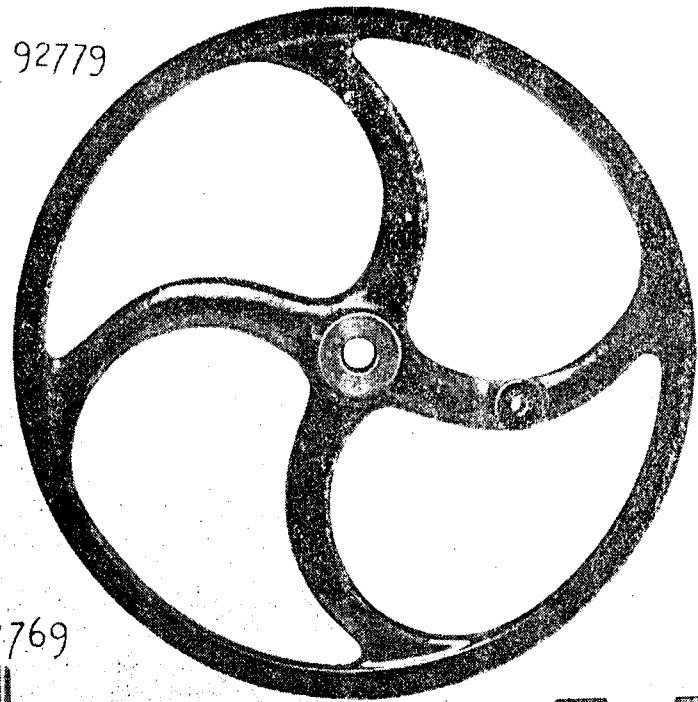

92769



92767

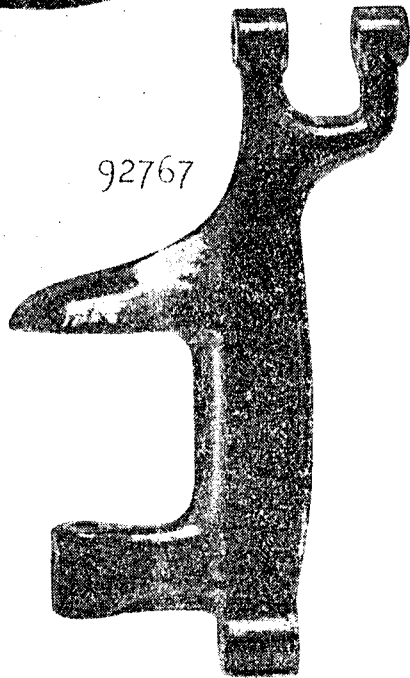

84275

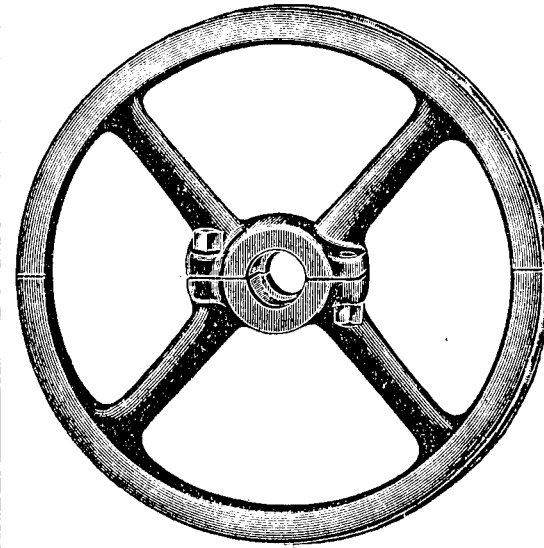

From the library of: Diamond Needle Corp

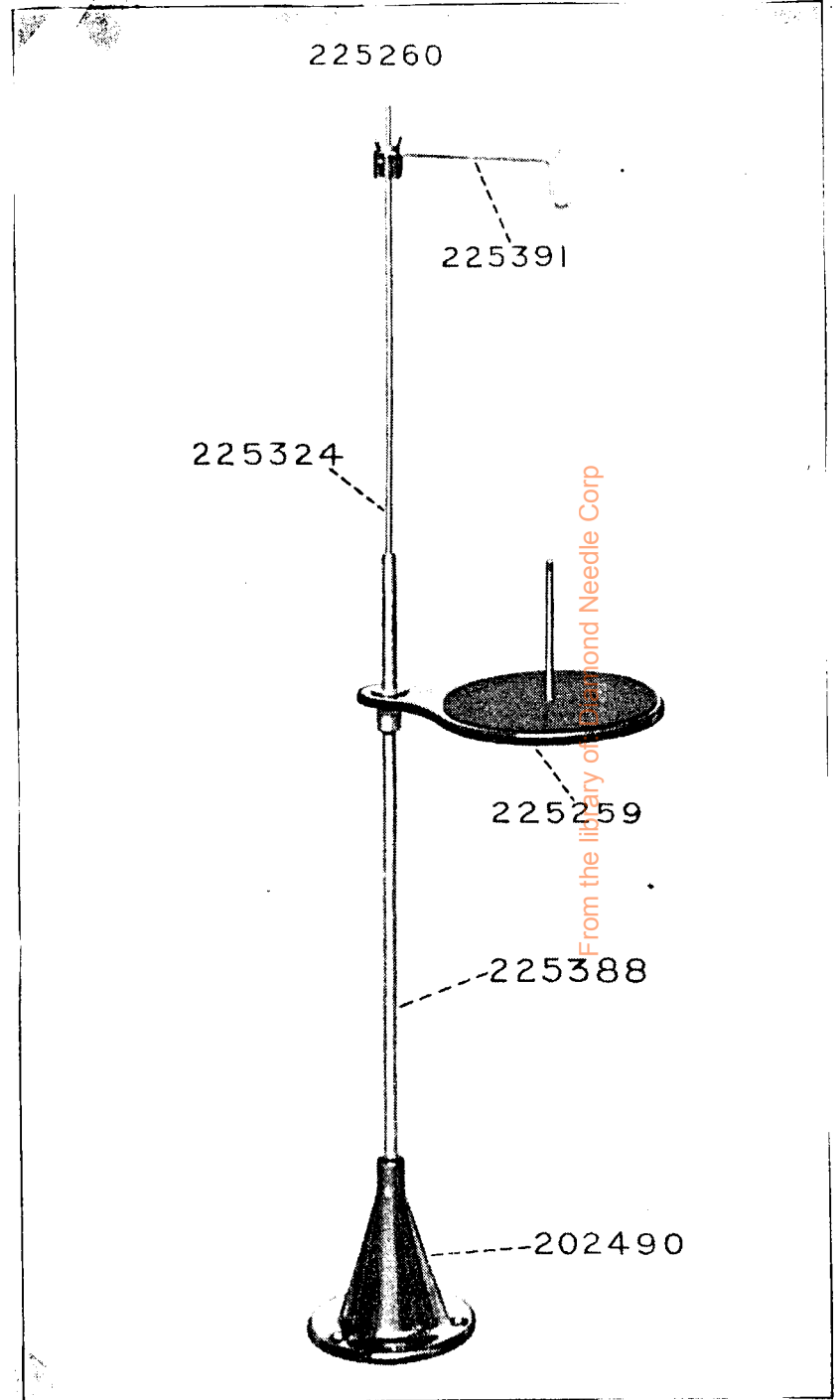
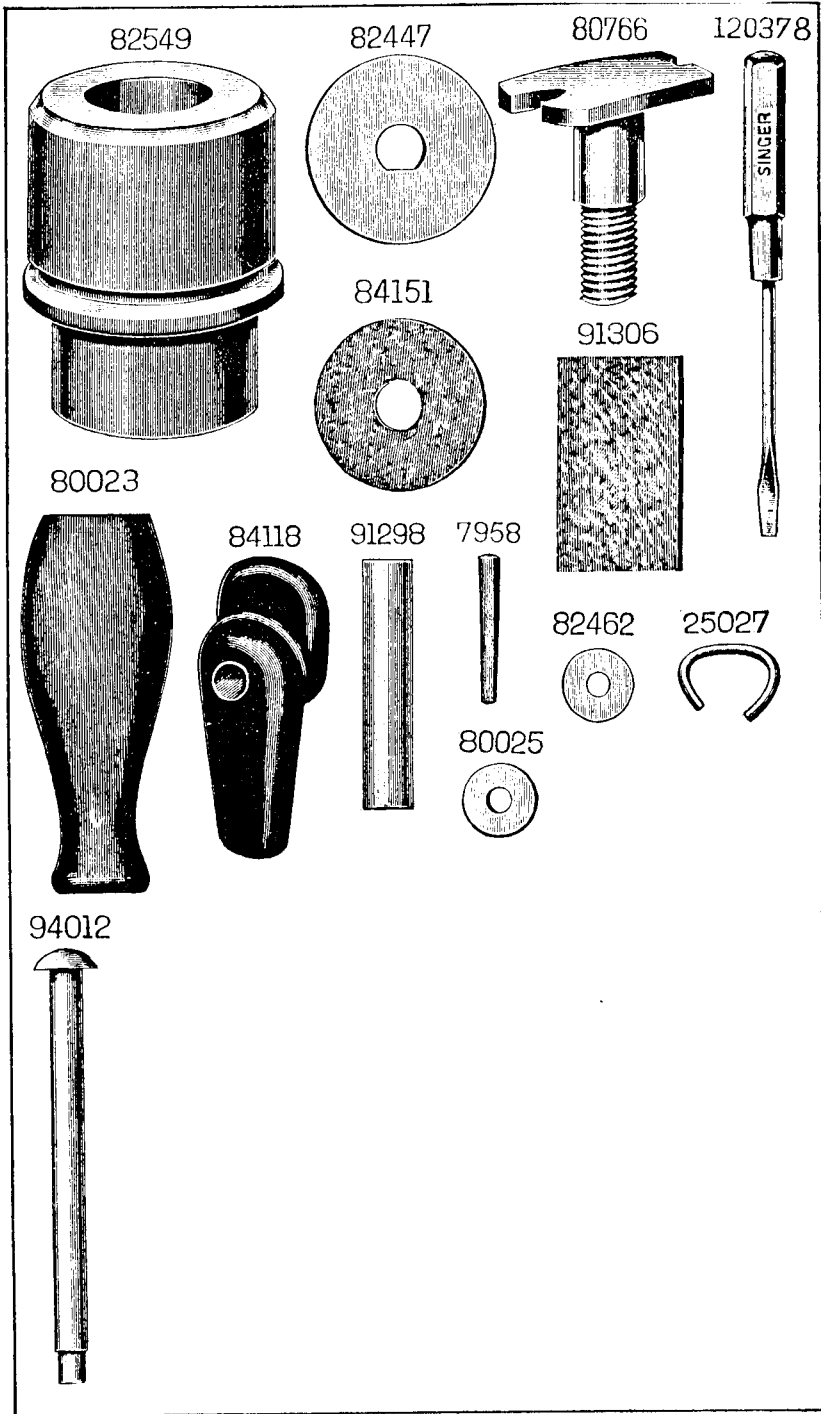

INSTRUCTIONS FOR ORDERING

In ordering from this List, the prefix and affix letters with the part number **MUST BE** quoted exactly as they are shown in the first column.

A number always indicates the same part in whatever List it may appear, or for whatever machine.

The prefix *SS* indicates Screws made only at Singer.

" " *NN* " Nuts made only at Singer.

" " *RR* " Rollers and Studs made only at Singer.

The affix letters (where shown) indicate the style of finish, as follows :—

- A. Hardened, Polished, Nickel Plated and Buffed.
- B. Polished, Nickel Plated and Buffed.
- C. Hardened only.
- C.R. Hardened and Merlized.
- D. Polished only.
- E. Soft, not Polished.
- F. Hardened and Polished.
- F.J. Hardened, Polished and Nickel Plated.
- G. Bright Rumbled and Nickel Plated.
- H. Blued.
- J. Nickel Plated only.
- K. Hardened and Nickel Plated.
- L. Brass Plated.
- M. Oxidized.
- N. Japanned, Dull.
- P. Japanned, Bright.
- R. Merlized.
- S. Cadmium Plated.
- T. Copper Plated.
- T.A. Hardened, Polished, Copper and Nickel Plated and Buffed.
- T.B. Copper and Nickel Plated and Polished.
- T.J. Copper and Nickel Plated only.
- T.K. Hardened, Copper and Nickel Plated.
- T.L. Copper and Brass Plated.
- T.M. Copper Plated and Oxidized.
- U. Zinc Plated.
- V. Silver Plated.
- W. Polished and Nickel Plated.
- X. Black Oxide for Iron and Steel.
- X.G. Hardened and Black Oxide for Iron and Steel.
- Y. Black Nickel Plated only.
- Z. Chromium Plated.
- Z.A. Hardened, Polished, Nickel Plated, Buffed and Chromium Plated.
- Z.B. Polished, Nickel Plated, Buffed and Chromium Plated.
- Z.C. Hardened and Chromium Plated.
- Z.G. Bright Rumbled, Nickel Plated, Bright Rumbled and Chromium Plated.
- Z.J. Nickel and Chromium Plated.

Parts marked with an asterisk () are furnished only when the repairs are made at Factory.*

PARTS COMPLETE

FOR

No. 47K1 MACHINE

CONTENTS

	Page
Parts, complete, for No. 47K1 Machine	43
" Special to No. 47K3 Machine	51
" " " " 47K5 "	53
Accessories	54
Bobbin Winder	54
Obsolete Parts	57
Singer Driving Attachment	55
Thread Unwinder	56
Numerical List of Parts	61

Overseaming with Top and Bottom Feed, 10" from Needle to Base of Arm, extra large Cylinder Shuttle with 4" Shuttle Race ; greatest throw of the Needle, 3/8"

No.	Plate	
*92790	—	Arm with 446c, 15404, 82549, 92792 and two 15405
8702	2157	" Dowel Pin (2)
868c	432	" Screw (front) (2)
118c	432	" " (back)
92835	—	Arm Shaft
92792	624	" " Bushing (back)
82549	2161	" " " (front)
116c	432	" " " Set Screw
92794	418	" " Driving Pinion with 454c
8937	624	" " " " Pin
154c	432	" " " " Set Screw
82400	420	" " Oil Tube
524c	433	" " Screw for Balance Wheels Nos. 92795 and 92796
SS433c	433	" " " " machine when fitted with Driving Attachment
82402	414	Arm Side Cover
51224d	432	" " " Thumb Screw
92607	418	" Thread Guide (front)
82450	418	" " " (side)
193d	432	" " " Screw
92795	412	Balance Wheel (two-speed) with two 434c (for use with Steam Power)
92796	—	" " (heavy) with two 434c (for use on Stand or Foot Power)
434c	432	" " Set Screw
*92609	—	Bed

Get the library of: Diamond Needle Corp

No.	Plate						
33949	417	Cam Bevel Gear
92842	—	" " "	33949 with SS577c
92610	417	" " "	Driving Bevel Pinion with two 453c
453c	432	" " "	" " " Set Screw
SS577c	2157	" " "	Hinge Screw
92611	423	" " "	Quadrant with RR43, two each 207c and 85325
92612	423	" " "	" " Collar with 209c
209c	432	" " "	" " Set Screw
RR43	433	" " "	" " Roller and Screw Stud
207c	432	" " "	" " Stop Screw
85325	423	" " "	" " " Washer
92613	412	Crank Connecting Rod with two 92614 and four 896c
*92614	—	" " "	Cap
896c	432	" " "	" " Screw
92615	414	Gross-over Cam Cover Plate
207d	432	" " "	" " Screw (2)
92616	414	" " "	Pitman
92617	417	" " "	Joint
35d	432	" " "	" " Hinge Screw
248c	432	" " "	" " Position Screw
SS127d	433	" " "	" " Screw
92618	417	" " "	" " Bush
NN52d	433	" " "	" " Thumb Nut
85709	423	" " "	" " " Washer
92806	720	Face Plate
145c	432	" " "	Screw (4)
92802	—	Face Plate , complete, Nos. 448c, SS601d, 82448, 82450, 82455, 92687, 92806, 92810 to 92812, 92820 and two 207d
92797	414	Feed Bar
92704	424	" " "	Retaining Spring
92623	424	" " "	" " Hook
588c	432	" " "	" " Screw
313c	432	" " "	Screw Centre (2)
1519e	433	" " "	" " Nut (2)
3032	423	Feed Cam with 446c
446c	432	" " "	Set Screw
52165	410	Feed Connecting Link
375c	432	" " "	" " Hinge Screw (2)
1518e	433	" " "	" " " Nut (2)

No.	Plate						
92798	428	Feed Dog
SS39c	433	" " "	Screw
92626	414	Feed Forked Connection
372c	432	" " "	Hinge Screw
1518e	433	" " "	" " " Nut
92627	412	Feed Lifting Rock Shaft with RR14
92628	—	" " "	" " 92627 with 92629
92629	425	" " "	" " Crank with RR46 and 453c
3012	424	" " "	" " " Pin
RR46	433	" " "	" " " Roller and Stud
300c	432	" " "	" " " Screw Centre
1513j	433	" " "	" " " " Nut
453c	432	" " "	" " " Set Screw
8396	423	" " "	" " " Stationary Centre
92631	422	" " "	" " " Raising Cam with 446c
3012	424	" " "	" " " " Pin
446c	432	" " "	" " " Set Screw
RR44	433	" " "	" " " Roller and Stud
91017	417	Feed Regulator
1128c	432	" " "	Hinge Screw
SS115d	433	" " "	Thumb Screw
92632	412	Feed Rock Shaft
92633	—	" " "	" " 92632 with 92634
92634	423	" " "	" " Crank with 453c
3012	424	" " "	" " " Pin
453c	432	" " "	" " " Set Screw
300c	432	" " "	" " " Screw Centre (2)
1513j	433	" " "	" " " Nut (2)
92636	2157	Guide
SS115d	433	" " "	Thumb Screw
91091	414	Needle Bar
92640	414	" " "	Connecting Link Guide
161d	432	" " "	" " " Screw (2)
92638	417	" " "	" " Connection with two 446c
92639	417	" " "	" " Link with SS44c
SS44c	433	" " "	" " Adjusting Screw
377c	432	" " "	" " " Hinge Screw
1518e	433	" " "	" " " " Nut
446c	432	" " "	" " " Set Screw
92641	414	" " "	Frame
300c	432	" " "	" " Screw Centre (short)
295c	432	" " "	" " " (long)
1513j	433	" " "	" " " Nut (2)

No.	Plate						
92642	417	Needle Clamp with 156c
156c	432	" " Set Screw
92649	423	Oscillating Shuttle Driving Shaft
SS128c	433	" " " " Ball End Screw Stud
1513j	433	" " " " " " " " Nut
92650	417	" " " " Fork with 446c
446c	432	" " " " " " Set Screw
92646	424	" " " " " Pin
92643	420	Oscillating Shuttle Shaft
92644	—	" " " Crank
92645	418	" " " " 92644 with 446c, 1519c and 92648
92646	424	" " " " Pin
446c	432	" " " " Set Screw
92647	418	" " " " Slide Block
190d	418	" " " " " " Cap Screw
5968	418	" " " " " " " " Washer
SS247c	418	" " " " " " Screw Stud
1519c	433	" " " " " " " " Nut
92648	418	Oscillating Shuttle Shaft Crank Slide Block, complete, Nos. 190d, SS247c, 5968 and 92647
92818	2158	Presser Bar (round)
92651	419	" " (flat)
199c	2157	" " (") Hinge Hub Cap Screw
34d	432	" " Position Hinge Screw for 92651
91075	422	Presser Bar Spring
92654	426	" " " Bracket with 1285c
1285c	432	" " " " Set Screw
92655	425	Presser Bar Lifter
SS186d	433	" " " Hinge Screw
1518c	433	" " " " " Nut
92656	424	" " " Stop Pin
252d	432	" " " Thumb Screw
NN45c	433	" " " " " Locking Nut
92662	—	Presser Foot Bracket
92606	424	" " " Hinge Pin
92663	—	" " Sole (serrated)
92664	427	Presser Foot (serrated) (two short toes), complete, Nos. 92606, 92662 and 92663

No.	Plate						
92662	—	Presser Foot Bracket
92606	424	" " " Hinge Pin
92667	—	" " Sole (plain)
92668	427	Presser Foot (plain, two short toes), complete, Nos. 92606, 92662 and 92667
157c	2157	Presser Foot Screw
1547c	433	" " " Nut
<i>NOTE: Nos. 92661 and 92668 are supplied with this machine.</i>							
92669	421	Shuttle Bobbin
92821	2156	" Cylinder
92671	421	" " Bobbin Pin
92673	421	" " Latch Spring
207d	432	" " " " Screw
92822	2156	" Frame
8777	2156	" " Hinge Pin
92675	429	" Tension Spring
SS103c	433	" " " Screw
92823	2156	Shuttle (cylinder), complete, Nos. SS103c, 207d, 8777, 92669, 92671, 92673, 92675, 92821 and 92822
92785	416	Shuttle Race with 92682 and two 7958
118c	432	" " Bearing Binding Screw (2)
92786	416	" " Cap
7958	2161	" " " Pin
92787	416	" " " Spring
32d	432	" " " " Screw
92788	416	" " Loop Spreader
401f	432	" " " " Screw
92682	424	" " Position Pin
92789	—	Shuttle Race (adjustable), complete, Nos. 32d, 401f and 92785 to 92788
92677	422	Shuttle Driver
92678	424	" " Pin
92679	413	Shuttle Slide
92815	624	Tension Release Bracket
159e	432	" " " Screw
92816	624	" " Lever
176d	432	" " " Binding Screw
82462	2161	" " " " " Washer
92804	—	Tension Release , complete, Nos. 159c, 92815, 92816 and two each 176d and 82462

No.	Plate						
92807	---	Thread Controller Lever
SS601d	2157	" "	" Hinge Screw
92808	---	" "	" Wheel
92809	---	" "	" Pin
92810	624	Thread Controller Lever, complete, Nos. 92808, 92809 and two 92807
92820	2157	Thread Controller Regulator
207d	432	" "	" Screw
92812	624	" "	" Spring
82455	424	" "	" Stop Pin
92811	624	" "	" Stud
448c	432	" "	" Set Screw
82448	423	" "	" Wheel
82450	418	Thread Guide
207d	432	" "	" Screw
89363	624	Thread Retainer Disc
412c	2157	" "	" Screw Stud
1560d	433	" "	" Regulating Thumb Nut
82445	423	" "	" Spring
92687	---	Thread Retainer, complete, Nos. 412c, 1560d, 82445 and two 89363
92839	2158	Thread Take-up Cam with two 446c
3012	424	" "	" Pin
446c	432	" "	" Set Screw
92837	2157	Thread Take-up Lever
92838	---	" "	" 92837 with RR24, SS328c, 1519c and 92814
SS22d	433	" "	" Hinge Screw
92814	624	" "	" Roller
SS328c	624	" "	" Hinge Screw
RR24	433	" "	" and Screw Stud
1519c	433	" "	" Nut
92694	428	Throat Plate
92695	428	" "	" Needle Plate
914d	2157	" "	" Screw
92696	428	Throat Plate, complete, Nos. 914d, 92694 and 92695, for 92798
92694	428	Throat Plate
92697	---	" "	" Needle Plate (fine needle hole)
914d	2157	" "	" Screw
92698	---	Throat Plate, complete, for Fine Overscaming Stitching, Nos. 914d, 92694 and 92697, for 92798

No.	Plate						
92694	428	Throat Plate
92699	---	" "	" Needle Plate (for straight stitching)
914d	2157	" "	" Screw
92700	---	Throat Plate, complete, for Straight Stitching, Nos. 914d, 92694 and 92699, for 92798
SS45d	433	Throat Plate Screw (2)
<i>NOTE. No. 92696 is supplied with this machine unless otherwise specified on order.</i>							
92701	419	Top Feed Cam with two 446c
92702	---	" "	" Lever Quadrant
92703	420	" "	" " " " " 92702 with RR23, 85325, 92705 and two 207d
3012	424	" "	" Pin
19510	2157	" "	" Retaining Spring
86c	2157	" "	" Screw
RR23	433	" "	" Roller
92705	424	" "	" Pin
207d	432	" "	" Stop Screw (top)
207d	432	" "	" (bottom)
85325	423	" "	" Washer
92706	419	" "	" Shaft
92707	419	" "	" Collar with 453c (2)
453c	432	" "	" Collar Set Screw
92708	419	" "	" Pitman
80774	426	" "	" Bushing
92819	426	" "	" Hinge Quadrant Bolt
80767	426	" "	" Washer
NN81d	433	" "	" Wing Nut
372c	432	" "	" Screw
1518c	433	" "	" Nut
193c	432	" "	" Retaining Spring Screw
446c	432	" "	" Set Screw
92709	412	" "	" Side Shaft
92710	---	" "	" 92709 with 92711
92711	420	" "	" Crank with 453c
92646	424	" "	" Pin
453c	432	" "	" Set Screw
304c	432	" "	" Screw Centre (2)
1513j	433	" "	" Nut (2)
92712	424	" "	" Side Shaft Joint
92713	424	" "	" Cap
202c	432	" "	" Screw (2)
1513j	433	" "	" Nut
92714	424	" "	" Washer

From the library of Needle & Thread Co. Ltd.

No.	Plate						
92715	415	Upright Shaft
92716	418	" " Bevel Pinion with 453c
3012	424	" " " " Pin
453c	432	" " " " Set Screw
92718	413	" " Bracket
130e	432	" " " Screw
92719	432	" " Crank Disc with 446e
SS128c	433	" " " " Ball End Screw Stud
1513j	433	" " " " " " " Nut
3012	424	" " " " Pin
446c	432	" " " " Set Screw
92720	419	Vibrating Presser Bar Cam with 446c
92721	---	" " " " Lubricator (felt)
175	432	" " " " " Screw
85325	423	" " " " " Washer
3012	424	" " " " Pin
446c	432	" " " " Set Screw
92722	415	" " " " Lever
7d	432	" " " " Hinge Screw
92817	424	" " " " Piston Joint
8589	424	" " " " " Pin
92783	---	" " " " Plunger
92724	424	" " " " " 92783 with RR45 and 92727
92725	424	" " " " " Hinge Pin
92726	---	" " " " " Oil Lubricator (felt)
RR45	433	" " " " " Roller
92727	424	" " " " " Pin
92723	---	Vibrating Presser Bar Lever , complete, Nos. 7d, 8589, 92722, 92724 to 92726 and 92817
*15404	---	Trade Mark
15405	---	" " Rivet
92801	---	Drip Pan

PARTS SPECIAL

TO

No. 47K3 MACHINE

Overseaming with Top and Bottom Feed, etc., fitted for Grommet Work

This machine is the same as No. 47K1 with the following exceptions :-

No.	Plate						
92799	430	Feed Dog
92734	429	Presser Bar (flat)
92781	415	" " (round)
161c	432	" " Screw (2)
92735	429	" " Spring Bracket with 446c
92736	429	Presser Foot (for plain eyeletting)
92737	429	" " (for metal ring eyeletting)
92738	430	" " (serrated)
191c	432	" " Screw for 92736 and 92737
<i>NOTE: Nos. 92736 and 92737 are supplied with this machine.</i>							
92739	2158	Shuttle Race with 92682 and two 7958
92740	2158	" " Cap
92741	---	Shuttle Race (adjustable), complete, Nos. 32d, 401f, 92739, 92740, 92787 and 92788
92742	430	Throat Plate
92743	430	" " Needle Plate with 92758
207d	432	" " " " Screw
92758	---	" " " " Spur, $\frac{1}{8}$ "
92744	---	Throat Plate for $\frac{1}{4}$ " Grommet, complete, Nos. 92742, 92743 and two 207d
92742	430	Throat Plate
92764	430	" " Needle Plate with 92745
207d	432	" " " " Screw
92745	---	" " " " Spur, $\frac{3}{8}$ "
92746	430	Throat Plate for $\frac{3}{8}$ " Grommet, complete, Nos. 92742, 92764 and two 207d

No.	Plate	
92742	430	Throat Plate
92747	--	" " Needle Plate
92748	430	" " " " 92747 with 202c and 92749
207d	432	" " " " Screw
92749	--	" " " " Spur, $\frac{1}{2}$ "
202c	432	" " " " " Screw
92750	--	Throat Plate for $\frac{1}{2}$ " Grommet, complete, Nos. 92742, 92748 and two 207d
92742	430	Throat Plate
92747	--	" " Needle Plate
92751	--	" " " " 92747 with 202c and 92752
207d	432	" " " " Screw
92752	429	" " " " Spur, $\frac{3}{8}$ "
202c	432	" " " " " Screw
92753	--	Throat Plate for $\frac{5}{8}$ " Grommet, complete, Nos. 92742, 92751 and two 207d
92742	430	Throat Plate
92747	--	" " Needle Plate
92754	--	" " " " 92747 with 202c and 92755
207d	432	" " " " Screw
92755	429	" " " " Spur, $\frac{3}{8}$ "
202c	432	" " " " " Screw
92756	--	Throat Plate for $\frac{3}{4}$ " Grommet, complete, Nos. 92742, 92754 and two 207d
92757	429	Top Feed Cam Side Shaft Joint

NOTE.—Nos. 92744 and 92764 are supplied with this machine unless otherwise specified on order.

PARTS SPECIAL TO No. 47K5 MACHINE

Overseaming with Top and Bottom Feed, etc. Greatest throw of the Needle, $\frac{9}{32}$ "

This machine is the same as No. 47K1 with the following exceptions:

No.	Plate	
92824		Presser Foot Adjusting Plate
2371	432	" " " " Screw
92825		" " Sole (serrated)
92826	1011	Presser Foot (serrated, two short toes), complete, Nos. 2371, 92606, 92662, 92824 and 92825
92824		Presser Foot Adjusting Plate
2371	432	" " " " Screw
92827		" " Sole (plain)
92828	1011	Presser Foot (plain, two short toes), complete, Nos. 2371, 92606, 92662, 92824 and 92827
<i>NOTE. Nos. 92826 and 92828 are supplied with this machine.</i>		
92829	1011	Shuttle Race Loop Spreader
92830	--	Shuttle Race (adjustable), complete, Nos. 32d, 4011, 92785 to 92787 and 92829
92840	2158	Thread Take-up Cam with two 446c
92832	1011	Throat Plate Needle Plate
92833		Throat Plate , complete, Nos. 914d, 92694 and 92832, for 92798
92834	1011	Upright Shaft Crank Disc with 446c

From the library of: Diamond Needle Corp

ACCESSORIES

No.	Plate	
84118	2161	Machine Button with 84151 and wood screw 1 1/4" No. 9 R.H.B. ...
84151	2161	" " Washer (leather) ...
214 1	-	Needles (6) three each sizes 23 and 24, for 47K5 Machine ...
214 1	-	" (3) size 27, for 47K1 Machine ...
214 3	-	" (3) " 28, " 47K1 " ...
214 9	-	" (6) three each sizes 26 and 27, for 47K3 Machine ...
120342	1600	Oiler ...
		Punch (for eyelets) (supplied according to size of Grommet) for 47K3 Machine ...
86611	1600	Screw Driver, 5" blade ...
120378	2161	" " (shuttle tension) ...
92669	421	Shuttle Bobbin (N) 2 ...
91268	429	Wrench for NN 45 ...

BOBBIN WINDER

No.	Plate	
92779	2159	Bobbin Winder Driving Wheel ...
92841	---	" " " " 92779 with 80023 and 94012 ...
92780	---	" " " " Belt, 26 1/2" long, with 25027 ...
25027	2161	" " " " " Hook ...
80023	2161	" " " " " Handle ...
94012	2161	" " " " " Spindle ...
80025	2161	" " " " " " Washer (brass) ...
SS81d	433	" " " " " Stud Screw ...
92767	2159	" " " " " Frame ...
SS80c	433	" " " " " Clamping Screw ...
92768	2157	" " " " " " Button ...
92769	2159	" " " " " Spindle ...
92770	2157	" " " " " Pulley ...
92771	412	Bobbin Winder (hand), complete, Nos. SS80c, SS81d, 80025, 92767 to 92770, 92780 and 92841 ...

SINGER DRIVING ATTACHMENT

No.	Plate	
92800	431	Balance Wheel (10" diam.) with SS432c, 434c and 92775 ...
92773	431	" " Friction Pulley (two-speed) with 416c and 92774 ...
92774	431	" " " " Centre Bearing ...
92775	-	" " " " Ring (leather) ...
416c	432	" " " " Set Screw ...
434c	432	" " " " Set Screw (long) ...
SS432c	433	" " " " (short) ...
91296	431	Foot Lever ...
91297	431	" " Bracket ...
91298	2161	" " " Hinge Pin ...
		" " " Screw (wood) 1 1/4" No. 15 ...
91300	431	" " Chain, 36 1/2" long, with 91304 and 91305 ...
91304	431	" " " Hook (small) ...
91305	431	" " " " (large) ...
91299	431	" " Nos. 91296 to 91298 and three wood screws 1 1/4" No. 15 ...
91323	-	Foot Lever, complete, 91299 with 91300 ...
92776	431	Lever with 91306 and 91308 ...
91302	431	" Bracket ...
SS38c	431	" " Screw ...
91303	431	" Centre Plug (wood) ...
427c	431	" " " Adjusting Screw ...
1508c	431	" " " " " Nut ...
91306	2161	" Friction Pad (leather) ...
693d	431	" Hinge Screw ...
NN28c	431	" " " Nut ...
91307	431	" Spring ...
161c	431	" " Screw ...
91308	431	" " " Pin ...
92777		Lever, complete, Nos. NN28c, SS38c, 161c, 427c, 693d, 1508c, 91302, 91303, 91307 and 92776 ...
84275	2160	Shaft Pulley (sectional, grooved), 10" diam., with two 597c ...
597c	432	" " Clamping Screw ...
92778	---	Driving Attachment , complete, Nos. 84275, 91323, 92773, 92777 and 92800 ...

From the library of: Diamond Needle Corp

THREAD UNWINDER FOR ONE LARGE SPOOL OF THREAD

No.	Plate	
84147	412	Spool Pin
84148	412	" Rest with 448c
84149	412	Thread Eyelet Rod
448c	432	" " " Set Screw
84150	412	Thread Unwinder, complete, Nos. 84147 to 84149 and two wood screws $\frac{3}{8}$" No. 10

Thread Unwinder

For One Spool of Thread.

225259	2212	Spool Rest with 201018c
150203	---	" " Cushion (felt)
225388	2212	" " Rod
200383c	---	" " " Set Screw
201018c	---	" " Set Screw
202490	2212	" Stand with 200383c
225391	2212	Thread Guide
201696j	---	" " Lock Nut
225326	---	" " Position Cup
225324	2212	" " Rod with 208c and 225322
208c	---	" " " Screw
225322	---	" " " Washer
225260	2212	Thread Unwinder, complete, Nos. 150203, 201696j, 202490, 225259, 225324, 225326, 225388, 225391, and three wood screws $\frac{3}{8}$ " No. 12
27739	---	Thread Cone (wood) for large cones
225390	---	" " Holder for inverted cones

NOTE.—Nos. 27739 and 225390 are used with, but not included in 225260.

OBSOLETE PARTS

No.	Plate	
92760		Arm Shaft for 47K1 Machine
92602		" " " 47K1 and 47K3 Machines
92791	412	" " "
92603	425	" " Bushing (back) with 446c for 47K1 and 47K3 Machines
92604	425	" " " (front) for 47K1 and 47K3 Machines
92793	624	" " " (")
92761	425	" " Driving Pinion with 454c for 47K1 Machine
92605	---	" " " " " 454c for 47K1 and 47K3 Machines
92606	424	" " " " Pin
82404	412	Balance Wheel (two-speed) with two 434c (for use with steam power) for 47K1 and 47K3 Machines
91002		" " (heavy) with two 434c (for use on stand or foot power) for 47K1 and 47K3 Machines
7289		Cam Bevel Gear for 47K1 and 47K3 Machines
92619	413	Face Plate for 92620
92620		Face Plate, complete, Nos. 207d, 446c, 82455, 82502, 91062, 92619, 92686 and 92687 for 47K1 Machine
92732		Face Plate for 92733
92733		Face Plate, complete, Nos. 207d, 446c, 82455, 82502, 91062, 92686, 92687 and 92732 for 47K3 Machine
92621		Feed Bar for 47K1 and 47K3 Machines
92728		Feed Cam with 446c for 92729
92729	418	" " 92728 with 8589 for 47K3 Machine
92730	418	" " Clutch Collar with 453c for 47K3 Machine
8589	424	" " " " Engaging Pin for 92729
92624	426	Feed Dog for 47K1 Machine
92625	---	" " " 47K1 "
92731		" " " 47K3 "
92635	420	Guide for 47K1 Machine
92762	420	Oscillating Shuttle Shaft Crank with 1801 for 47K1 Machine
92657	---	Presser Foot Bracket for 92659, 92661 and 92666
92658	---	" " Sole (serrated) for 92659
92659	426	Presser Foot (serrated, one long and one short toe), complete, Nos. 92606, 92657 and 92658 for 47K1 Machine
92660	---	Presser Foot Sole (serrated) for 92661
92661	427	Presser Foot (serrated, two long toes), complete, Nos. 92606, 92657 and 92660 for 47K1 Machine
92665	426	Presser Foot Sole (plain) for 92666
92666	426	Presser Foot (plain, two long toes), complete, Nos. 92606, 92657 and 92665 for 47K1 Machine

OBSOLETE PARTS

No.	Plate	
92670	421	Shuttle Cylinder for 92676
92674	421	" Frame for 92676
92672	421	" " Hinge Pin for 92676
92676	421	Shuttle (cylinder), complete, Nos. SS103c, 207d and 92669 to 92675 for 47K1 and 47K3 Machines
92680	415	Shuttle Race with 92682 and 92683 for 92685
92681	415	" " Cap for 92685
92684	429	" " Loop Spreader for 92685
92683	424	" " Retaining Spring Hook for 92680
92685	—	Shuttle Race (adjustable), complete, Nos. 401f, 92680, 92681, 92684 and four SS45c for 47K1 Machine
92782	421	Shuttle Tension Spring for 47K1 Machine
82445	423	Tension Spring for 82502
82446	423	" Washer (felt) for 82502
82447	2161	" " (steel) for 82502
82448	423	" Wheel for 82502
82502	—	Tension , complete, Nos. SS317e, 1560d, 82445, 82448, two each 82446 and 82447 for 92620 and 92733
91280	423	Tension Washer for 47K1 Machine
92686	426	Thread Controller for 92620 and 92733
46d	432	" " Lever Hinge Screw for 92802
92784	423	Thread Retainer Bracket for 47K1 Machine
80548	423	" " Spring for 47K1 and 47K3 Machines
92688	—	Thread Take-up Cam with 446c for 47K1 and 47K3 Machines
92805	—	" " " " two 446c for 47K1 and 47K3 Machines
92836	425	" " " " " 446c " 47K1 " 47K3 "
92831	1011	" " " " " 446c " 47K5 Machine
92689	—	Thread Take-up Lever for 92690
92690	424	" " " 92689 with RR24 and 1519e for 47K1 and 47K3 Machines
92813	—	" " " for 92803
92803	624	" " " 92813 with RR24, SS328c, 1519e and 92814
91062	423	" " Spring (heavy) for 92620 and 92733
82455	424	" " " Stop Pin for 92620 and 92733
92691	—	Throat Plate for 92693
92692	423	" " Needle Plate for 92693
92693	413	Throat Plate, complete, Nos. 92691, 92692 and two 207d for 92624, for 47K1 Machine
80766	2161	Top Feed Cam Pitman Hinge Quadrant Bolt for 47K1 and 47K3 Machines
92765	—	Upright Shaft Bracket for 47K1 Machine
92766	424	" " " Bevel Pinion with 453c for 47K1 Machine